



BENTON CLEAN AIR AGENCY

Benton Clean Air Agency, 526 S. Steptoe St. Kennewick, WA. 99336

IN THE MATTER OF THE COMPLIANCE
BY Atlas Agro North America Corporation
with Chapter 70A.15 RCW and the
Regulations of the Benton Clean Air Agency

ORDER of APPROVAL No. 2024-008

TO: Atlas Agro North America Corporation
723 The Parkway
Richland, WA 99352

Issue Date: June 2, 2025

Permittee: Atlas Agro North America Corporation. The Permittee is required to comply with the provisions contained within this Order of Approval.

Responsible Official: Kaustav Chaudhuri, Project Manager, Atlas Agro
Phone: 949-529-4421

Technical Contact: Kaustav Chaudhuri, Project Manager, Atlas Agro
kaustav.chaudhuri@atlasagro.ag
Phone: 949-529-4421

Source Location: Atlas Agro North America Corporation's "Pacific Green Fertilizer Plant" to be located at 3501 Stevens Dr. Richland 99354 in Benton County, WA. Parcel ID: 110081000001004.

1. JURISDICTION AND LEGAL AUTHORITY:

This Order of Approval (Order/Permit) is issued under the authority of Revised Code of Washington (RCW) 70A.15.2040 (3) and in accordance with RCW 70A.15.2210, Washington Administrative Code (WAC) 173-400-110, WAC 173-460-040, and Benton Clean Air Agency (BCAA) Regulation 1.

2. PROJECT DESCRIPTION:

Atlas Agro North America Corporation, hereafter referred to as Atlas Agro, the Permittee, the Facility or the Source, is proposing to construct and operate a new nitrate-based fertilizer plant in Richland, WA. at the above location. The Project will include various process units that will produce hydrogen, oxygen, ammonia, nitric acid, and ammonium nitrate as shown in Figure 3 below.

Crushed calcium carbonate and dolomite (calcium carbonate and magnesium carbonate) will be shipped to the plant site via railroad and stored in silos prior to processing. These products and raw materials will be used in chemical formulation to produce calcium ammonium nitrate (CAN) granules and calcium nitrate (CN) liquid, in addition to ammonium nitrate solution (ANSOL) as fertilizer products, as shown in the process flow diagram in Figure 4 below. These products will be distributed to local and regional markets.

Atlas Agro proposes to use state-of-the-art production equipment to produce up to a maximum of 650,000 metric tons per year of zero-carbon nitrogen fertilizers.

The Facility is to be located in Richland, Washington at 130-acre site. Vicinity map and the site plan locations are shown in Figures 1 and 2 below.

To support the production of these fertilizer products, additional equipment units will be installed, including an ammonia plant startup heater, an auxiliary boiler, a cooling tower, an emergency flare, emergency generator engines, and an emergency firewater pump among other utilities as shown in Figures 4 and 5 below.

3. FINDINGS:

The proposed Facility qualifies as a new source of air contaminants and is required to undergo New Source Review (NSR) in accordance with RCW 70A.15.2210, WAC 173-400-110 and WAC 173-460-040.

The Facility has the potential to emit Nitrogen Dioxide (NO₂) above 100 tons per year if operating at 8760 hours annually, which exceeds the major source threshold, which categorizes the Facility as a major source. Therefore, it is required to obtain a Title V permit pursuant to the Federal Clean Air Act (FCAA) and WAC 173-401 - Operating Permit Regulation. However, the Facility has requested to opt-out of the Title V program by limiting its potential air emission through restriction on the number of operating hours for some of its process units, as specified in this Order and pursuant to WAC 173-400-091. Table 4 in appendix A below shows the potential air emissions sitewide with and without the requested enforceable limit. Therefore, the Facility will be synthetic Source under this Order and will be classified as a synthetic minor source, which imposes federally enforceable limits pursuant WA 173-400-030(38), BCAA Regulation 1 and WAC 173-400-091.

For the ammonia plant, the Facility will be using the Haber-Bosch process. This process uses fixed-bed reactors filled with iron “fixed-bed iron”. The reactor operates at a very high temp (400-500 °C) and high pressure to promote the reaction of H and N gases. The gases pass through heat exchange and are cooled by a refrigeration system, forming liquid ammonia. Then liquid ammonia is stored in double wall tanks prior to pumping it into the ammonium nitrate and nitric acid plants.

For the nitric acid plant, the Facility will be using the Ostwald process. In this process, ammonia is mixed with oxygen, normally, in a ratio of one to eight in a catalyst gauze (copper gauze) chamber/reactor to produce NO and water. The NO continues to oxidize and passes through heat exchanger to lower the temperature, then continues oxidizing in the pipelines to NO₂. In another absorption tower containing water, NO₂ is absorbed, in which nitric acid (HNO₃) is formed. HNO₃ is then absorbed in the tower. Produced HNO₃ will be stored in tanks with off and on specification. Initial HNO₃ is 30% percent then to 60% in the second cycle/reactor off and on specification, respectively. In this process, exhaust gases so called “tail gases, e.g., NO, NO₂, N₂O” will pass through Selective Catalytic Reduction (SCR) unit with ammonia to reduce the NO_x emissions prior to venting to atmosphere.

For the Calcium Nitrate Unit, crushed limestone will be combined with a HNO₃ solution in four (4) hours batch reactors to produce liquid calcium nitrate. Air emissions from this process are in the forms of NO_x and CO₂. Each of the two batch reactors has a four (4) hour cycle.

A State Environmental Policy Act (SEPA) Checklist was submitted to the City of Richland on February 5, 2024. A Determination of Non-Significance (DNS) was issued on April 18, 2024.

Air Emissions:

Criteria Air Pollutant (CAP) emissions from the Facility include Nitrogen Dioxide (NO₂), Carbon Monoxide (CO), Sulfur Dioxide (SO₂), particulate matter (PM), fine particulate matter with an aerodynamic diameter less than or equal to 10 microns (PM₁₀), fine particulate matter with an aerodynamic diameter of less than or equal to 2.5 microns (PM_{2.5}), and Volatile Organic Compounds (VOC's).

Toxic air pollutant (TAP) emissions from the Facility that exceed the applicable small-quantity emission rate (SQER) include Ammonia (NH₃), Nitrogen Dioxide (NO₂), Cadmium, Diesel Engine Exhaust Particulate, and Hexavalent Chromium known also as Chromium VI. All TAPs and HAPs air emissions are shown in Tables 2 and 3 in Appendix A below, respectively.

APPLICABLE LAWS AND REGULATIONS:

- 3.1 Unless otherwise stated, the applicable dates for the referenced Code of Federal Regulations (CFRs), RCWs, and WACs are those applicable at the time of issuance of this Order.
- 3.2 The Facility shall comply with RCW 70A.15, Washington Clean Air Act and RCW 43.21C, State Environmental Policy Act (SEPA), and WAC 197-11, SEPA Rules.

- 3.3 The Facility shall comply with WAC 173-400, General Regulations for Air Pollution Sources; WAC 173-460, Controls for New Sources of Toxic Air Pollutants.
- 3.4 The Facility shall comply with 40 CFR Part 60- Subpart A: General Provisions.
- 3.5 The Facility shall comply with 40 CFR Part 60, Subpart Dc- Standards of Performance for Small Industrial-Commercial-Institutional Steam Generating Units.
- 3.6 The Facility shall comply with 40 CFR Part 60, Subpart Ga- Standards of Performance for Nitric Acid Plants for Which Construction, Reconstruction, or Modification Commenced After October 14, 2011.
- 3.7 The Facility shall comply with 40 CFR Part 60, Subpart IIII- Standards of Performance for Stationary Compression-Ignition Internal Combustion Engines.
- 3.8 The Facility shall comply with 40 CFR Part 63, Subpart ZZZZ- National Emission Standards for Hazardous Air Pollutants for Stationary Reciprocating Internal Combustion Engines.
- 3.9 The Facility shall comply with 40 CFR Part 63, Subpart A- General Provisions.
- 3.10 The Facility shall comply with BCAA Regulation 1.
- 3.11 The Facility shall comply with all additional applicable federal, state and local rules and regulations in Washington State. It is the responsibility of the Facility to know all other applicable regulations which could be applicable or become applicable, at all times.

AMBIENT AIR QUALITY:

- 3.12 The Facility is within an area that is unclassifiable with respect to the national ambient air quality standards (NAAQS) for NO₂, CO, SO₂, and PM₁₀, PM_{2.5} and Ozone.
- 3.13 Impacts to the Wallula PM₁₀ maintenance area have been modeled using an EPA-approved AERMOD dispersion model. Based on what was submitted, the Facility meets the applicable requirements of WAC 173-400-113(3).
- 3.14 Estimated TAPs emitted from the Facility have been modeled using an EPA-approved AERMOD dispersion model for pollutants that have been determined to be above the Small Quantity Emission Rates (SQER) and the impacts were determined to be below the Acceptable Source Impact Level (ASIL) listed in WAC 173-460.
- 3.15 Impacts to the ambient air quality have been modeled using an EPA-approved AERMOD dispersion model. The Facility will not cause or contribute to a violation of the National or State ambient air quality standard.
- 3.16 The proposed Facility, if constructed and operated as submitted in the Notice of Construction (NOC) application, along with the additional submitted information and all approval conditions herein, as required, will not result in the exceedance of any ambient air quality standards.

BEST AVAILABLE CONTROL TECHNOLOGY (BACT) AND BEST AVAILABLE CONTROL TECHNOLOGY FOR TOXICS (t-BACT):

As required by WAC 173-400-113(2) and 173-460-040(3)(a), the proposed Facility's emission unit(s) shall use BACT and t-BACT to control emissions of criteria pollutants and toxic air pollutants, respectively. The BCAA considers the following to be BACT and t-BACT:

Nitric Acid Unit:

BACT and t-BACT for the nitric acid unit, as proposed by Atlas Agro, shall use Selective Catalytic Reduction (SCR) system which will be using NH₃ to convert NO₂ and NO into N and a Scrubber to control air emissions from the nitric acid storage tanks with the following limits:

- 3.17 The SCR shall have a NO_x control efficiency of at least 98% reduction.
- 3.18 NO_x emissions shall be limited to 10.4 lb/hr (normal operations) and 705 lb/hr (startup and shutdown), startup and shutdown operations must be limited to a maximum of 3 hours per calendar year and as specified in the operation conditions below.
- 3.19 NO_x emissions shall be limited to 20 parts per million by volume (ppmv) during normal operation. Maximum emissions from NAU of 47 tons per year, including startup and shutdown.
- 3.20 NO_x as NO₂ shall not exceed 0.5 pounds per ton of nitric acid produced for a rolling average of 30 consecutive days pursuant to NSPS limits of 40 CFR Part 60, Subpart Ga.
- 3.21 NH₃ emissions shall be limited to 0.022 lb/hr.

Calcium Ammonium Nitrate (CAN) Unit:

BACT for the CAN unit, as proposed by Atlas Agro, shall be using baghouses with the following limits for material handling, granulation, and drying processes:

- 3.22 The baghouses shall have an efficiency of at minimum, 99.9%.
- 3.23 PM₁₀ and PM_{2.5} emissions will be limited to 3.2 lb/hr and a maximum of 5 percent (5%) opacity on a 6-minute average (normal operations).
- 3.24 PM₁₀ and PM_{2.5} emissions will be limited to 34.5 lb/hr during startup and shutdown, which must be limited to 48 hours per calendar year and a maximum of 5 percent (5%) opacity on a 6-minute average.
- 3.25 VOC emissions will be limited to low-VOC- CAN granule coatings. Granular coating shall not exceed any of the concentration and composition limits specified in the submitted safety data sheet (SDS) with the NOC application, at all times. VOC concentration shall not exceed 0.29% by weight. The trade name at the SDC is DUSTROL® 7030-T; supplier Armaz chemical SAS; Identified uses, Dust Control /Anti-Caking Aid.

Ammonia Unit Fugitives:

Ammonia emissions from the ammonia units are predicted to be mainly through leaks as fugitives from the valves, compressors, pumps, etc. BACT and t-BACT for the fugitive leaks from the ammonia unit shall be as proposed by Atlas Agro and BCAA as follows:

- 3.26 Development of visual inspection for leak detection and repair program. This program shall include inspection of accessible pipe and pump components as the presumptive BACT for this unit.
- 3.27 This program shall be part of the Operation and Maintenance (O&M) plan and shall be approved by BCAA.
- 3.28 BCAA determines that gas infrared camera e.g., FLIR, G series or similar products shall be used to detect any gas leaks from pipes and connection, valves etc., as part of BACT. The infrared gas camera, the kind/model and its applicability shall be approved by BCAA, prior to purchase and use.

Emergency Flare:

Atlas Agro proposes the following as presumptive BACT for the emergency flare which uses Hydrogen as the main fuel for the pilot flame and natural gas as a backup fuel. The flare will be used only to provide emergency relief for the hydrogen plant, ammonia unit, ammonia storage tank, and ammonium nitrate unit. The proposed flare has the following:

- 3.29 An elevated open flare stack with an ignition system at the base and flare tip at the top.
- 3.30 The flare will be operated with a continuously operating pilot burner with a rated heat input no greater than 0.14 MMBtu/hr to flare any gas that is detected or directed to the flare during an emergency.
- 3.31 Smokeless flare design.
- 3.32 Good combustion practices. To maintain constant flow gas, NH₃ sweep gas (max. heat input 0.85 MMBtu/hr) will be continuously supplied to the header system to prevent buildup of oxygen and pipes backflow.
- 3.33 The open flare shall be working as proposed and in accordance with what was provided by the Permittee including its combustion and destruction efficiencies, but should not be less than 96.5 and 98 percent, respectively.

Nitric Acid Storage Tanks:

Atlas Agro proposes BACT for the nitric acid off- and on-specification of the HNO₃ storage tanks as follows:

- 3.34 Wet scrubber system that uses weak HNO₃ scrubbing liquid to absorb NO_x to capture gases vented from the HNO₃ main storage tank and startup storage tank exhausts.
- 3.35 The NO_x air emissions from the wet scrubber for the storage tanks shall be limited to 200 ppmv.

- 3.36 The wet scrubber from the storage tanks has a maximum exhaust flow rate of 31,995 cubic feet per hour.

Calcium Nitrate Unit (CNU):

The proposed presumptive BACT for the calcium nitrate unit batch reactors as follows:

- 3.37 The reactor will use a wet scrubber which uses weak HNO₃ scrubbing liquid to absorb NO_x from the reactor's exhaust.
- 3.38 The wet scrubber at the calcium nitrate unit batch reactors will reduce NO_x air emissions and shall have an efficiency of at least 98% reduction.
- 3.39 NO_x emissions from CNU shall not exceed 9.8 pounds per hour for a maximum of 4100 hours per year from the two reactors.

Hydrogen-Fired Auxiliary Boiler/Heater:

The proposed presumptive BACT for the ammonia unit startup heater and the auxiliary boiler which uses Hydrogen as the main fuel and natural gas as backup fuel are as follows:

- 3.40 NO_x emissions limited to 50 ppm using low NO_x burners.
- 3.41 CO emissions limited to 125 ppm using low NO_x burner.
- 3.42 Using Hydrogen (main) and natural gas (backup) as fuel.

Diesel Emergency Engines and Fire Water Pump:

The proposed presumptive BACT for all pollutants emitted by the diesel emergency engines are as follows:

- 3.43 The two proposed diesel-powered emergency generators shall use EPA Tier 4 certified engines.
- 3.44 The proposed diesel-powered fire water pump, BACT will be EPA Tier 2 certified engine.
- 3.45 The Facility will also operate and maintain the engines as recommended by the manufacturer.
- 3.46 All engines shall use ultra-low sulfur diesel with 0.0015% by weight.
- 3.47 The maximum number of operating hours for non-emergency generators and the fire water pump is limited to 29 hours per year (maintenance and testing purposes).

Cooling Towers:

The proposed presumptive BACT for PM₁₀ and PM_{2.5} emissions from the cooling towers are as follows:

Using counter-current dry air by limiting the maximum total dissolved solids concentration of the cooling water to 800 ppm by weight.

- 3.48 Employing high-efficiency mist eliminators with a design drift rate of 0.0005 percent (0.0005%) to minimize water droplet loss.

Material Transfer:

The proposed presumptive BACT for PM₁₀ and PM_{2.5} emissions from the limestone and dolomite (calcium carbonate and magnesium carbonate) storage silos, CAN product storage, and CAN product loadout to storage bins as follows:

- 3.49 Baghouses designed with limited emissions to a maximum of 0.0044 gr/dscf.
- 3.50 The Facility shall use high efficiency filters bags e.g., MERV 16 or higher.
- 3.51 Opacity limited to a maximum of 5 percent (5%) on a 6-minute average using 40 CFR Part 60 Appendix A, Method 9 for point source and Method 22 for fugitive air emissions.
- 3.52 All conveyers transferring raw materials shall be enclosed.

CAN Product Loadout Fugitives:

The proposed presumptive BACT for fugitive PM₁₀ and PM_{2.5} emissions from CAN truck loadout operations is as follows:

- 3.53 Using telescoping loadout spouts with skirts to minimize and reduce fugitive emissions during loadout.
- 3.54 BCAA determines that it shall also have a maximum of five percent (5%) visible emission during loadout.

Roadway Fugitives:

The proposed presumptive BACT for fugitive dust emissions entrained by vehicles is as follows:

- 3.55 Limit the traveling vehicle to operate mainly on paved surfaces.
- 3.56 Develop and implement a fugitive dust control plan to minimize dust buildup on paved surfaces when vehicles are operated.

- 3.57 The plan shall be approved by BCAA and be part of the O&M plan as specified by this Permit.
- 3.58 Travelling speed limits (10 mph) shall be posted.
- 3.59 Unpaved roads shall use dust palliative materials or water, as needed.

4. DETERMINATION:

The following determination has been made, based on the review of the NOC submitted on July 10, 2024, and the additional information requested on August 19, 2024, which was received on September 9, 2024, and any other subsequent information including those submitted on December 3, 2024:

It is determined that the Facility has the potential to emit nitrogen dioxide (NO₂) above 100 tons annually (8760 hours of operation per year). This potential exceeds the major source threshold, categorizing the Facility as major source. Therefore, the Facility is Title V pursuant to the Federal Clean Air Act (FCAA) and WAC 173-401. However, the Facility has requested a limit on the number of hours of operation for some of its process units as specified in this Order and shown in Tale 4 below, Appendix A. Therefore, the Facility and pursuant to RCW 70A.15.2040(3), WAC 173-400-091, WAC 173-401-300(7) and BCAA regulation 1, shall be classified as a synthetic minor source with limits imposed on number of hours of operation, and air emissions limits, as specified in this Order and as requested by the Facility. Table 2 and 3 are the expected emissions for the TAPs and HAPs, respectively and are shown Appendix A.

The proposed project, if constructed and operated with the limits as described in this Order, the submitted NOC application and the additional requested submitted information shall be in accordance with applicable rules and regulations set forth in Chapter 173-400 WAC, 173-460 WAC and 173-401 WAC. Additionally, operation of this Facility at the proposed location will not result in an exceedance of an ambient air quality standard.

The proposed project, if constructed and operated as described in this Order with all approved control equipment as specified in application and this Order, will provide all known, available, and reasonable methods of emission control.

THEREFORE, it is ordered that the proposed project, as described in the NOC Application, additional submitted requested information, this Order, and more specifically detailed plans, specifications, and all other information submitted to the BCAA, is approved for construction, installation, and operation, **PROVIDED** that, the equipment specification submitted with NOC application and the approval conditions outlined in this Order are met.

This Order shall become effective upon receipt by the Permittee or by the effective date, unless appealed within thirty (30) days of receipt as specified in section 6 of this Order.

5. SPECIFIC APPROVAL CONDITIONS:

5.1 EMISSION LIMITS:

Facility-wide emissions shall not exceed the specified limits shown in Table 1 below.

Table 1. Facility-wide emissions limits.

Condition	Pollutant	Emission Source	Emission Limit ton per year (tpy)
5.1.1	Nitrogen Oxides (NO _x) as mainly NO ₂ and NO		74 tpy (<i>Facility-Wide</i>)
		Ammonia Plant Startup Heater	0.21 tpy
		Nitric Acid Unit	47 tpy
		Nitric Acid Unit Storage Tank & Scrubber	3.2 tpy
		Calcium Nitrate Unit Scrubber	20.09 tpy
		Emergency Flare (normal operation)	2.9 tpy
		Auxiliary Boiler	0.36 tpy
		Diesel-Fired Emergency Generator #1 (maintenance and testing)	0.02 tpy
		Diesel-Fired Emergency Generator #2 (maintenance and testing)	0.05 tpy
Diesel-Fired Fire Water Pump (FWP) (maintenance and testing)	0.05 tpy		
5.1.2	Carbon Monoxide (CO)		2.5 tpy (<i>Facility-Wide</i>)
		Ammonia Plant Startup Heater	0.32 tpy
		Emergency Flare (normal operation)	1.2 tpy
		Auxiliary Boiler	0.54 tpy
		Diesel-Fired Emergency Generator #1 (maintenance and testing)	0.11 tpy
		Diesel-Fired Emergency Generator #2 (maintenance and testing)	0.25 tpy
Diesel-Fired Fire Water Pump (FWP) (maintenance and testing)	0.04 tpy		
5.1.3	Sulfur Dioxide (SO ₂)		0.011 tpy (<i>Facility-Wide</i>)
		Ammonia Plant Startup Heater	3.03E-03 tpy
		Emergency Flare (normal operation)	2.6E-03 tpy
		Auxiliary Boiler	5.0E-03 tpy
		Diesel-Fired Emergency Generator #1 (maintenance and testing)	2.0E-04 tpy
		Diesel-Fired Emergency Generator #2 (maintenance and testing)	4.6E-04 tpy
Diesel-Fired Fire Water Pump (FWP) (maintenance and testing)	5.7E-07 tpy		
5.1.4	Particulate Matter		29 tpy
		Ammonia Plant Startup Heater	3.8E-02 tpy
		CAN Unit Granulator Stack	14.8 tpy
		CAN Unit Raw Material Receiving to Silos	0.43 tpy
		CAN Products Storage Dust Collectors	2.8 tpy

Condition	Pollutant	Emission Source	Emission Limit ton per year (tpy)
		Emergency Flare (normal operation)	3.2E-02 tpy
		Auxiliary Boiler	6.4E-02 tpy
		Diesel-Fired Emergency Generator #1 (maintenance and testing)	9.2E-04 tpy
		Diesel-Fired Emergency Generator #2 (maintenance and testing)	2.2E-03 tpy
		Diesel-Fired Fire Water Pump (FWP) (maintenance and testing)	2.4E-03 tpy
		Cooling Tower	1.0 tpy
		Product Load-out Fugitive Emissions	8.2 tpy
		Paved Road Fugitive Emissions	1.6 tpy
5.1.5	Particulate Matter (PM ₁₀)		28 tpy (Facility-Wide)
		Ammonia Plant Startup Heater	3.8E-02 tpy
		CAN Unit Granulator Stack	14.8 tpy
		CAN Unit Raw Material Receiving to Silos	0.43 tpy
		CAN Products Storage Dust Collectors	2.8 tpy
		Emergency Flare (normal operation)	3.2E-02 tpy
		Auxiliary Boiler	6.4E-02 tpy
		Diesel-Fired Emergency Generator #1 (maintenance and testing)	9.2E-04 tpy
		Diesel-Fired Emergency Generator #2 (maintenance and testing)	2.2E-03 tpy
		Diesel-Fired Fire Water Pump (FWP) (maintenance and testing)	2.4E-03 tpy
		Cooling Tower	0.85 tpy
		Product Load-out Fugitive Emissions	8.2 tpy
		Paved Road Fugitive Emissions	0.32 tpy
5.1.6	Particulate Matter (PM _{2.5})		19 tpy (Facility-Wide)
		Ammonia Plant Startup Heater	3.8E-02 tpy
		CAN Unit Granulator Stack	14.8 tpy
		CAN Unit Raw Material Receiving to Silos	0.43 tpy
		CAN Products Storage Dust Collectors	2.8 tpy
		Emergency Flare (normal operation)	3.2E-02 tpy
		Auxiliary Boiler	6.4E-02 tpy
		Diesel-Fired Emergency Generator #1 (maintenance and testing)	9.2E-04 tpy
		Diesel-Fired Emergency Generator #2 (maintenance and testing)	2.2E-03 tpy
		Diesel-Fired Fire Water Pump (FWP) (maintenance and testing)	2.4E-03 tpy
		Cooling Tower	3.7E-03 tpy
		Product Load-out Fugitive Emissions	0.82 tpy
		Paved Road Fugitive Emissions	0.08 tpy
5.1.7	Volatile Organic Compounds (VOCs)		5.5 tpy (Facility-Wide)
		Ammonia Plant Startup Heater	2.8E-02 tpy
		CAN Unit Granulator Stack	5.3 tpy
		Emergency Flare (normal operation)	2.3E-02 tpy

Condition	Pollutant	Emission Source	Emission Limit ton per year (tpy)
		Auxiliary Boiler	4.6E-02 tpy
		Diesel-Fired Emergency Generator #1 (maintenance and testing)	0.01 tpy
		Diesel-Fired Emergency Generator #2 (maintenance and testing)	0.01 tpy
		Diesel-Fired Fire Water Pump (FWP) (maintenance and testing)	0.05 tpy
5.1.8	TAPs Emissions		
		Ammonia	43.85 tpy
		Cadmium & Compounds, NOS	0.176 tpy
		Chromium (VI) & compounds, NOS	0.003 tpy
5.1.9	Visible Emissions	<p>Specific Unit Opacity: As indicated in each process, specified in this Order and indicated in the approval conditions herein.</p> <p>Facility-Wide: General visible emissions when not specified in this Order, shall not exceed 20 percent (20%) opacity averaged over (6) minutes as measured pursuant to 40 CFR 60 Appendix A Method 9 for point source or Method 22 for fugitive source. Or as measured by Department of Ecology method 9A for more than 3 minutes in one hour as specified in WAC 173-400-040(2)-General standards for maximum emissions.</p>	

5.2 EMISSION LIMITS from the NITRIC ACID PLANT (Unit):

Nitric acid plant produces nitric acid using Ostwald process as explained above in the findings. Produced HNO₃ will be stored in tanks with off and on specification. In this process, exhaust gases so called “tail gases” will pass through SCR unit with week ammonia to reduce the NO_x emissions prior to venting to atmosphere. Controls of the air emission from the nitric acid plant will be using SCR system as stated above in the BACT. Therefore, the emissions limits shall not exceed the following:

- 5.2.1 During normal operations, emissions shall not exceed 10.4 lb /hr (during normal operations). A total of 47 tons per year, which include Startup, Shutdown and Malfunction (SSM) of NO_x i.e., NO₂ and NO from the tail gases as stated above based on 12 months rolling average.
- 5.2.2 At the startup and shutdown of the unit, it shall not exceed 705 pounds per hour for a maximum of 1.5 hours per year per event, and no more than two events per year. This means a maximum of 3 hours per 12 months rolling average. As emissions will be higher during unit startup and shutdown because the exhaust temperature will be very low for SCR catalyst to function properly. Thus, startup and shutdown mean when the exhaust temperature of the SCR is below the specified manufacturers temperature. This temperature must be submitted to BCAA before the start of the operation or when the design operating manual is known and available to the Facility.

- 5.2.3 During the startup and shutdown of the unit the maximum NO_x at the stack shall not exceed 1500 ppmv for a maximum of 1.5 hours per event for two events per year as specified in this Order.
- 5.2.4 Ammonia (NH₃) emission, from the SCR unit from the tail gases i.e., is so called “ammonia slip” as unreacted ammonia from the SCR unit shall not exceed 0.022 pounds per hour.
- 5.2.5 NO_x as NO₂ emissions from the nitric acid plant shall not exceed 0.5 pounds per ton of nitric acid produced based on rolling average of a consecutive 30 days, the production being expressed as 100 percent nitric acid. This emission standard applies at all times, on and after the date on which the performance test required to be conducted by 40 CFR Part 60, Subpart Ga § 60.73a(e) is completed. Standard means as per 40 CFR §60.72a, is a thirty (30) day emission rate calculated based on thirty (30) consecutive operating days and production expressed as 100% nitric acid. The standard applies at all times.
- 5.2.6 Emissions limits from the nitric acid unit during normal operation shall not be below 98% efficiency at any time except as specified in the startup and shutdown.

5.3 EMISSIONS LIMITS, from the Ammonium Nitrate Plant:

- 5.3.1 There shall be no air emissions from the ammonium nitrate plant.

5.4 EMISSION LIMITS from Calcium Ammonium Nitrate Unit (CAN) Unit Operation:

This operation limit includes raw materials receiving and silos (limestones), truck loading and bulk storage unit.

- 5.4.1 All raw material that transferred pneumatically shall be in an enclosed system.
- 5.4.2 PM_{2.5} Emission limits from the silo's baghouses, bulk storage unit baghouses, truck loadout bin baghouses and CAN granulation baghouses shall be limited to less than 0.004 grain per cubic feet.
- 5.4.3 The CAN unit and all transfer points area shall be equipped with baghouses as specified and shown in Figure 4 below. PM_{2.5} limits for all baghouses units shall not exceed 0.004 grain per cubic feet.
- 5.4.4 Volatile Organic Compounds (VOC) from granulator and coating operation drum from the granulator stack shall not exceed 0.29 weight % in the coating materials which is a maximum of 1.21 pounds per hour.
- 5.4.5 The CAN products, e.g., bulk storage, truck loadout bins and all transfer points to the granulation area shall use baghouses with PM_{2.5} emission limit of less than 0.004 grain per cubic feet.

Opacity from the CAN operations units, including receiving, bulk storage, loadout materials and the silos, shall not exceed a maximum of five percent (5%) at all times based on 6 minutes average.

5.5 OPERATING REQUIREMENTS and LIMITS:

- 5.5.1 The Permittee shall follow all recommended operation and equipment maintenance provisions supplied by the manufacturer for each unit.
- 5.5.2 The backup auxiliary boiler (57 MMBtu/hr) shall not operate more than 300 hours per year.
- 5.5.3 The startup heater (34.2 MMBtu/hr) shall not operate for more than 300 hours per year.
- 5.5.4 The two diesel backup generators (1287 hp and 3017 hp) to provide power in case of power outage shall not exceed 29 hours per year for maintenance and testing.
- 5.5.5 The fire water pump (507 hp) provides water in case of fire and shall be limited to 29 hours per year for maintenance and testing.
- 5.5.6 The calcium ammonium nitrate (CAN) raw materials receiving to silos unit shall be limited to a maximum of 4186 hours per year.
- 5.5.7 The calcium ammonium nitrate (CAN) unit operates 8760.
- 5.5.8 The calcium nitrate unit (CNU) shall be limited to a maximum of 4100 hours per year.
- 5.5.9 The loadout products shall be limited to no more than 3,150 tons per day (10 hours per day), for a total of 819,000 (5days per week, 52 weeks per year) tons per year.
- 5.5.10 The Permittee must develop and implement site specific O&M plan for all the processes equipment and shall be part of the BACT for the whole Facility and all equipment control, i.e. SCR, baghouses, wet scrubber, flare etc. The O&M plan shall contain at least four sections: general information, operation plan (i.e., key operating parameters), maintenance plan, and any other additional information. The plan must be completed within 90 days from the first day of the starting normal operation, and shall also include at a minimum, but not limited to the following:
 - 5.5.10.1 Monitoring the physical condition of the baghouses, SCR, wet scrubber, etc. logs of any repairs and replacement, as soon as it is done, and the monthly, weekly or daily monitoring.
 - 5.5.10.2 The regular schedule of the inspections and maintenances for each processing unit, e.g. H and O₂ electrolysis unit, ammonia plant, nitric acid unit, ammonium nitrate unit, calcium carbonate silos and finished product loading etc.
 - 5.5.10.3 The checking for wear and tear e.g., the filter bags, etc.
 - 5.5.10.4 Specify the fixed-bed iron catalyst time-period changed out based on manufacturer and conditions.
 - 5.5.10.5 The weekly check and log of the pressure drop reading from all installed gauges while in operation for the baghouses.
 - 5.5.10.6 The range of the pressure drop while the baghouses in operation shall not be exceeded and shall be clearly marked on or besides the gauge based on manufacturer's recommendation. and

5.5.10.7 Change of the gauze at the nitric acid unit.

- 5.5.11 Opacity as measured by 40 CFR Part 60, Appendix A, Method 9 (point source) and Method 22 (fugitive point source), shall be conducted within 30 days from the startup of the operation and shall not exceed any respective opacity limit required in this Order, for an average for six (6) consecutive minutes in any given one-hour period, from the stack opening and from any fugitive dust point, respectively. The respective Opacity shall not be exceeded, when in operation, except during periods of startup, shutdown or malfunction as provided in WAC 173-400-081. If the opacity is greater than this limit the Permittee shall immediately stop the equipment in question or the operation and take corrective actions as per the O&M plan until visible emissions are below the respective opacity limit.
- 5.5.12 The Permittee must conduct visible emission inspections of the Facility at least once per month. Inspections are to be carried out while the facility is in operation during daylight hours. If during the monthly visible emissions inspection, visible emissions other than uncombined water are observed, from the specific units or operation, the Permittee must as soon as practicable but within 12 hours of the initial observation do the following:
- 5.5.12.1 Take corrective action, which may include shutting down the unit or operation until it can be repaired, and until there are no visible emissions (or until the unit or operation, is demonstrated to be in compliance with all applicable opacity limitations in this Order using the reference test method above); or
- 5.5.12.2 Alternatively, determine the opacity using the reference test method. If visible emissions are observed from a unit or an operation, make sure that the unit or operation are being operated and maintained properly and either shut it down within 3 hours or observe visible emissions using 40 CFR Part 60 Appendix A, Method 9 or Method 22, for stack opening or fugitive dust, respectively, within 24 hours. All observations using the opacity reference test method must be kept on-site and made available to BCAA staff during an inspection or upon request. If the Facility has no certified opacity reader, the Permittee shall contact the agency, and they will be advised accordingly.

5.6 COMPLIANCE DEMONSTRATION

- 5.6.1 Hours of operation and limits specified in this Order shall be recorded by the Facility and shall be easily verified at any time, during an inspection by BCAA staff, and must be submitted to the agency on a monthly basis, and it shall be received by the BCAA on or before the 10th day of the beginning of every month for any of the previous 30 consecutive days.
- 5.6.2 NO_x air emissions from the nitric acid unit shall be calculated daily including the nitric acid produced. Ammonia slip from the nitric acid unit SCR shall also be calculated daily. The daily nitric acid production of the facility must be recorded on an hourly and daily basis.

- 5.6.3 All genset diesel engines shall be equipped with a non-resettable hour meter, which shall be working at all times during operations. These meters must be easily reachable. The hour-meter reading must be submitted in writing to BCAA within 30 days prior to the start of the operation and the initial reading of the meter must be verified by BCAA staff prior to the start of the operation.
- 5.6.4 Every startup and shutdown of the nitric acid plant shall be recorded in the record keeping operations log. Each startup/shutdown log entry will contain at minimum: the date of the event, the start and end time of the startup or shutdown, and the reason for the startup or shutdown. A notification of the startup or shutdown event shall be submitted to BCAA within 12 hours by email and must include all of the information from the log entry, including the name of the operator sending the notification.
- 5.6.5 Startup and shutdown shall be defined per WAC 173-400-030. Startup shall be defined as starting when the gauze in the reactor is lit and shall not last longer than two hours per startup. Shutdown events will be defined as beginning when the operator cuts the NH₃ feed to the converter and shall end when the compressors are turned off.
- 5.6.6 Startup and shutdown shall be defined as per WAC 173-400-030(89) and (83). In addition, Atlas Agro shall define the startup and shutdown with the exact parameters and submit it to BCAA for approval.
- 5.6.7 The startup and shutdown for the nitric acid plant should also include when the temperature at the exhaust stack of the SCR is outside the recommended designed manufacturers setup temperature for the SCR.
- 5.6.8 The total quantity of the flared gas must be metered, recorded and logged. The record must be submitted to BCAA monthly, and the timing should coincide with the previous 30 consecutive days of the record for the nitric acid unit.

5.7 EMISSIONS MONITORING AND TESTING:

Nitric Acid Unit Emissions Monitoring Requirements:

- 5.7.1 Atlas Agro must install and operate a continuous emissions monitoring system (CEMS) for NO_x concentration measuring in ppmv from the nitric acid unit. In addition, Atlas Agro must also install and operate a stack gas flow rate monitoring system. Atlas Agro shall determine the hourly NO_x emissions rate (e.g., lb/hr) and measure the hourly nitric acid production data in pound or tons (lb or tons) and must calculate air emissions in units of the applicable emissions limit e.g., lb/ton of 100 percent acid produced. Atlas Agro must operate the monitoring system and report emissions during all operating periods including at the time of startup and shutdown, and malfunction and shall be based on hourly, daily, monthly and on twelve months rolling average periods. All values shall be based on continuous data as specified in 40 CFR Part 60 Subpart Ga, 60.73 (a) through (e).

Nitrogen Oxides Concentration Continuous Emissions Monitoring System (CEMS)

- 5.7.2 Atlas Agro must install, calibrate, maintain, and operate the CEMS for measuring and recording the concentration of NOX emissions in accordance with the provisions of § 60.13 and Performance Specification 2 of Appendix B and Procedure 1 of Appendix F of 40 CFR Part 60-Quality Assurance Procedures. Atlas Agro must use cylinder gas audits to fulfill the quarterly auditing requirement at section 5.1 pursuant to Procedure 1 of Appendix F of Part 60, 40 CFR for the NOX concentration at the CEMS.
- 5.7.3 For the NOX concentration CEMS, Atlas must use a span value, as defined in Performance Specification 2, section 3.11, of Appendix B of 40 CFR Part 60, of 500 ppmv (as NO₂). If Atlas Agro emit NOX at concentrations higher than 600 ppmv (which is the case during startup or shutdown periods), therefore, Atlas Agro must apply a second CEMS or dual range CEMS and a second span value equal to 125 percent of the maximum estimated NOX emission concentration to apply to the second CEMS or to the higher of the dual analyzer ranges during such periods.
- 5.7.4 For conducting the relative accuracy test audits, per Performance Specification 2, section 8.4, of Appendix B of 40 CFR Part 60, and Procedure 1, section 5.1.1, of Appendix F of 40 CFR Part 60, use either EPA Reference Method 7, 7A, 7C, 7D, or 7E of Appendix A-4 of this 40 CFR Part 60; EPA Reference Method 320 of appendix A of part 63 of this chapter; or ASTM D6348-03 (incorporated by reference, see § 60.17). To verify the operation of the second CEMS or the higher range of a dual analyzer CEMS described in paragraph (b)(2) of this section of 40 CFR Part 60 Subpart Ga (up to date as of 9/12/2024) Standards of Performance for Nitric Acid Plants for Which Construction, Reconstruction or Modification Commenced After October, 14, 2011, Atlas Agro need not conduct a relative accuracy test audit, but only the calibration drift test initially (found in Performance Specification 2, section 8.3.1, of appendix B of 40 CFR Part 60-performance specification) and the cylinder gas audit thereafter (found in Procedure 1, section 5.1.2, of appendix F of 40 CFR Part 60-Quality Assurance Procedures).
- 5.7.5 If Atlas Agro uses EPA Reference Method 7E of Appendix A-4 of 40 CFR Part 60, Atlas Agro must mitigate loss of NO₂ in water according to the requirements in paragraphs (b)(4)(i), (ii), or (iii) of section 60.73a and verify performance by conducting the system bias checks required in EPA Reference Method 7E, section 8, of Appendix A-4 of 40 Part 60, Subpart Ga according to (b)(4)(iv) of section § 60.73a, or follow the dynamic spike procedure according to paragraph (b)(4)(v) of section § 60.73a [for ease of reference 5.7.5.1 through 5.7.5.5]:
- 5.7.5.1 For a wet-basis measurement system, you must measure and report temperature of sample line and components (up to analyzer inlet) to demonstrate that the temperatures remain above the sample gas dew point at all times during the sampling.
- 5.7.5.2 The Permittee may use a dilution probe to reduce the dew point of the sample gas.

- 5.7.5.3 The Permittee may use a refrigerated-type condenser or similar device (e.g., permeation dryer) to remove condensate continuously from sample gas while maintaining minimal contact between condensate and sample gas.
- 5.7.5.4 If the analyzer measures nitric oxide (NO) and nitrogen dioxide (NO₂) separately, the Permittee must use both NO and NO₂ calibration gases. Otherwise, you must substitute NO₂ calibration gas for NO calibration gas in the performance of system bias checks.
- 5.7.5.5 The Permittee must conduct dynamic spiking according to EPA Reference Method 7E, section 16.1, of appendix A-4 of this 40 CFR Part 60, Subpart Ga using NO₂ as the spike gas.
- 5.7.6 Instead of an initial NO_x concentration for the CEMS in meeting Performance Specification 2, Atlas Agro may apply a Fourier Transform Infrared Spectroscopy (FTIR) FTIR CEMS meeting the requirements of Performance Specification 15 of appendix B of 40 CFR Part 60 to measure NO_x concentrations. Should Atlas Agro use FTIR CEMS, Atlas Agro must replace the Relative Accuracy Test Audit requirements of Procedure 1 of appendix F 40 CFR Part 60 with the validation requirements and criteria of Performance Specification 15, sections 11.1.1 and 12.0 of appendix B of 40 CFR Part 60.
- 5.7.7 On and after the date on which the performance test required to be conducted by § 60.73a(e) is completed, Atlas Agro may not discharge into the atmosphere from the affected facility any gases which contain NO_x, expressed as NO₂, in excess of 40 CFR §60.72a.

Determining NO_x Mass Emissions Rate Values

- 5.7.8 Atlas Agro must use the NO_x concentration CEMS, acid production, gas flow rate monitor and other monitoring data to calculate emissions data in units of the applicable limit (lb NO_x/ton of acid produced expressed as 100 percent nitric acid).
- 5.7.9 Atlas Agro must install, calibrate, maintain, and operate a CEMS for measuring and recording the stack gas flow rates to use in combination with data from the CEMS for measuring emissions concentrations of NO_x to produce data in units of mass rate (e.g., lb/hr) of NO_x on an hourly basis. Atlas Agro must operate and certify the continuous emissions rate monitoring system (CERMS) is in accordance with the provisions of 40 CFR Part 60 § 60.13 and Performance Specification 6 of Appendix B of 40 CFR Part 60. Atlas Agro must comply with the following provisions as also specified in 40 CFR Part 60, Subpart Ga in section 60.73a(c)(1)(i) through (iii) [for ease of reference 5.7.9.1 through 5.7.9.3]:
- 5.7.9.1 Atlas Agro must use a stack gas flow rate sensor with a full-scale output of at least 125 percent of the maximum expected exhaust volumetric flow rate (see Performance Specification 6, section 8, of appendix B of 40 CFR Part 60).

- 5.7.9.2 For conducting the relative accuracy test audits, per Performance Specification 6, section 8.2 of appendix B of 40 CFR Part 60 and Procedure 1, section 5.1.1, of appendix F of 40 CFR Part 60, you must use either EPA Reference Method 2, 2F, or 2G of appendix A-4 of 40 CFR Part 60. The Permittee may also apply Method 2H in conjunction with other velocity measurements.
- 5.7.9.3 Atlas Agro must verify that the CERMS complies with the quality assurance requirements in Procedure 1 of appendix F of 40 CFR Part 60. Atlas Agro must conduct relative accuracy testing to provide for calculating the relative accuracy for relative accuracy test audit (RATA) and relative accuracy audit (RAA) determinations in units of lb/hour as applicable in accordance with Procedure 1 of appendix F of 40 CFR Part 60.
- 5.7.10 Atlas Agro must determine the nitric acid production parameters (production rate and concentration) by installing, calibrating, maintaining, and operating a permanent monitoring system (e.g., weigh scale, volume flow meter, mass flow meter, tank volume) to measure and record the weight rates of nitric acid produced in tons per hour. If the Permittee's nitric acid production rate measurements are for periods longer than hourly (e.g., daily values), Atlas Agro will determine average hourly production values, tons acid/hour, by dividing the total acid production by the number of hours of process operation for the subject measurement period. Atlas Agro must comply with the following provisions as also specified in 40 CFR Part 60, Subpart Ga in section 60.73a (c)(2)(i) through (iv) [for ease of reference 5.7.10.1 through 5.7.10.4]:
- 5.7.10.1 Atlas Agro must verify that each component of the monitoring system has accuracy and precision of no more than ± 5 percent of the full scale.
- 5.7.10.2 Atlas Agro must analyze product concentration via titration or by determining the temperature and specific gravity of nitric acid. Atlas Agro may also use ASTM E1584-11 (incorporated by reference, see § 60.17), for determining the concentration of nitric acid in percent. Atlas Agro must determine product concentration daily.
- 5.7.10.3 Atlas Agro must use the acid concentration to express nitric acid production as 100 percent nitric acid.
- 5.7.10.4 Atlas Agro must record the nitric acid production, expressed as 100 percent nitric acid, and the hours of operation.
- 5.7.11 Atlas Agro must calculate hourly NO_x emissions rates in units of the standard (lb/ton acid produced) for each hour of process operation. For process operating periods for which there is little or no acid production (e.g., startup or shutdown), Atlas Agro must use the average hourly acid production rate determined from the data collected over the previous 30 days of normal acid production periods as specified in 40 CFR Part 60 Subpart Ga section 60.75a.

Continuous Monitoring System

- 5.7.12 For each continuous monitoring system, including NO_x concentration measurement, volumetric flow rate measurement, and nitric acid production measurement equipment, Atlas Agro must meet the following requirements:
- 5.7.12.1 Atlas Agro must operate the monitoring system and collect data at all required intervals at all times the affected Facility is operating except for periods of monitoring system malfunctions or out-of-control periods as defined in appendix F, sections 4 and 5, of 40 CFR Part 60, repairs associated with monitoring system malfunctions or out-of-control periods, and required monitoring system quality assurance or quality control activities including, as applicable, calibration checks and required zero and span adjustments.
- 5.7.12.2 Atlas Agro may not use data recorded during monitoring system malfunctions or out-of-control periods, repairs associated with monitoring system malfunctions or out-of-control periods or required monitoring system quality assurance or control activities in calculations used to report emissions or operating levels. Atlas Agro must use all the data collected during all other periods in calculating emissions and the status of compliance with the applicable emissions limit in accordance with 40 CFR Part 60 Subpart Ga, Section 60.72a "Nitrogen oxides. On and after the date on which the performance test required to be conducted by 40 CFR Part 60, Subpart Ga, section 60.73a(e) is completed, Atlas Agro may not discharge into the atmosphere from any affected facility any gases which contain NO_x, expressed as NO₂, in excess of 0.50 pounds (lb) per ton of nitric acid produced, as a 30-day emission rate calculated based on 30 consecutive operating days, the production being expressed as 100 percent nitric acid. The emission standard applies at all times."

Initial Performance Testing

- 5.7.13 Atlas Agro must conduct an initial performance test to demonstrate compliance with the NO_x emissions limit under 40 CFR Part 60 Subpart Ga, Section 60.72a (as stated above too) beginning in the calendar month following initial certification of the NO_x and flow rate monitoring CEMS. The initial performance test consists of a collection of hourly NO_x average concentration, mass flow rate recorded with the certified NO_x concentration and flow rate CEMS and the corresponding acid generation (tons) data for all of the hours of operation for the first 30 days beginning on the first day of the first month following completion of the CEMS installation and certification as described above. Atlas Agro must ensure that the CERMS meets all of the data quality assurance requirements as per section 60.13 and appendix F, Procedure 1, of 40 CFR Part 60 Subpart Ga, and Atlas Agro must use the data from the CERMS for this compliance determination.

- 5.7.14 The initial performance test must be conducted as per 40 CFR Part 60 Subpart Ga, Section 60.73a(e) to demonstrate compliance with the NO_x emission limit under § 60.72a(a) beginning in the calendar month following initial certification of the NO_x and flow rate monitoring CEMS.
- 5.7.15 Atlas Agro will submit the report results of all initial compliance demonstrations no later than 60 calendar days after completion of each respective source test. Including all handwritten notes during the source test.

Additional Source Testing

- 5.7.16 Emissions testing shall be required, at the discretion of the BCAA, at other times, and should be based on emission limits in Condition 5.1 or 5.2 and at least every five years thereafter or when required and as applicable pursuant to WAC 173-400-105(4) and WAC 173-400-075(2). All source testing, monitoring, and analytical methods for hazardous air pollutants shall conform with the requirements of 40 C.F.R. Parts 51, 60, 61, 62, 63 and 65, as applicable pursuant to WAC 173-400-075(3).
- 5.7.17 When complaint investigation, visible emission observations, or other information obtained by BCAA, indicates the need to measure air emissions, BCAA may require the Permittee to conduct source testing pursuant to WAC 173-400-105(4)
- 5.7.18 BCAA may conduct source tests and require access to records, books, files, and other information for compliance and enforcement specific to the control, recovery, or release of those pollutants regulated under 40 CFR Parts 61, 62, 63 and 65, as applicable.
- 5.7.19 All source testing, monitoring, and analytical methods for Atlas Agro must comply with the requirements of 40 CFR Parts 51, 60, 61, 62, 63 and 65, as applicable.

NITRIC ACID UNIT RECORDKEEPING AND REPORTING REQUIREMENTS

- 5.7.20 For the NO_x emissions rate, Atlas Agro must keep daily records and the results of the performance evaluations of the continuous emissions monitoring systems.
- 5.7.21 Atlas Agro must maintain records of at minimum the following information for the nitric acid unit:
 - 5.7.21.1 Hourly and Daily Hours of operation.
 - 5.7.21.2 Production rate of nitric acid expressed as 100 percent nitric acid.
 - 5.7.21.3 The average hourly and daily NO_x emissions rate values for a rolling average of 30 days of operation.
- 5.7.22 Atlas Agro must maintain records for the nitric acid unit of the following time periods:
 - 5.7.22.1 Times when Atlas Agro were not in compliance with the emissions standards at any time.

- 5.7.22.2 Times when the pollutant concentration exceeded the full span of the NOX monitoring equipment.
- 5.7.22.3 Times when the volumetric flow rate exceeded the high value of the volumetric flow rate monitoring equipment.
- 5.7.23 Atlas Agro must maintain records of the reasons for any periods of noncompliance and description of corrective actions taken.
- 5.7.24 Atlas Agro must maintain records of any modifications to CEMS which could affect the ability of the CEMS to comply with applicable performance standards and specifications.
- 5.7.25 For each malfunction, Atlas Agro must maintain at least records of the following information:
 - 5.7.25.1 Records of the occurrence and duration of each malfunction of operation (i.e., process equipment) or the air pollution control and monitoring equipment.
 - 5.7.25.2 Records of actions taken during periods of malfunction to minimize emissions in accordance with 40 CFR Part 60 Subpart A, § 60.11(d), (at all times, including periods of startup, shutdown, and malfunction...) including corrective actions to restore malfunctioning process and air pollution control and monitoring equipment to its normal or usual manner of operation.
 - 5.7.25.3 The process must be shut down immediately during any processes malfunction.
 - 5.7.25.4 All control equipment shall be in operation, at all times. No process shall be operating without the control equipment being in operation except as allowed during startup and shutdown and specified in the rules and regulations.
- 5.7.26 The performance test data from the initial and all subsequent performance tests and the performance evaluations of the continuous monitors must be submitted to EPA Administrator and to BCAA at the appropriate address as shown in 40 CFR 60.4. Region 10, Director, Air and Waste Management Division, U.S. Environmental Protection Agency, 1200 Sixth Avenue, Seattle, WA 98101. And Benton Clean Air Agency, Director, 526 South Steptoe Street. Kennewick, WA. 99336.
- 5.7.27 The following information must be reported to the Administrator and BCAA for each 30 days of operating period where Atlas Agro was not in compliance with the emissions standard:
 - 5.7.27.1 Time period.
 - 5.7.27.2 NOx emission rates (lb/ton of acid produced).
 - 5.7.27.3 Reasons for noncompliance with the emissions standard.
 - 5.7.27.4 Description of corrective actions taken.

- 5.7.28 Atlas Agro must also report the following whenever they occur:
- 5.7.28.1 Times when the pollutant concentration exceeded the full span of the NOX pollutant monitoring equipment.
 - 5.7.28.2 Times when the volumetric flow rate exceeded the high value of the volumetric flow rate monitoring equipment.
- 5.7.29 Atlas Agro must report any modifications to CERMS which could affect the ability of the CERMS to comply with applicable performance specifications.
- 5.7.30 Within 60 days of completion of RATA required by this Order in accordance with Procedure 1 of appendix F of 40 CFR Part 60, the Permittee must submit the data from that audit to EPA's WebFIRE database by using the Compliance and Emissions Data Reporting Interface (CEDRI) that is accessed through EPA's Central Data Exchange (CDX) (https://cdx.epa.gov/SSL/cdx/EPA__Home.asp). Atlas Agro must submit performance test data in the file format generated through use of EPA's Electronic Reporting Tool (ERT) (<http://www.epa.gov/ttn/chief/ert/index.html>). Only data collected using test methods listed on the ERT Web site are subject to this requirement for submitting reports electronically to WebFIRE. If any or some of the information being submitted for performance tests is confidential business information (CBI) must submit a complete ERT file including information claimed to be CBI on a compact disk or other commonly used electronic storage media (including, but not limited to, flash drives) by registered letter to EPA and the same ERT file with the CBI omitted to EPA via CDX as described earlier in this paragraph. Mark the compact disk or other commonly used electronic storage media clearly as CBI and mail to U.S. EPA/OAPQS/CORE CBI Office, Attention: WebFIRE Administrator, MD C404-02, 4930 Old Page Rd., Durham, NC 27703. Atlas Agro must also submit these reports to the BCAA. Atlas Agro must submit the other information as required in the performance evaluation as described in 40 CFR Part 60, subpart A and this Order.
- 5.7.31 If a malfunction occurred during the reporting period, Atlas Agro must submit a report that contains the following:
- 5.7.31.1 The number, duration, and a brief description for each type of malfunction which occurred during the reporting period, and which caused or may have caused any applicable emission limitation to be exceeded.
 - 5.7.31.2 A description of actions taken by Atlas Agro or operator during a malfunction of an affected Facility to minimize emissions in accordance with the compliance with standards and maintenance requirements as specified in 40 CFR Part 60, Subpart A section 60.11(d), including actions taken to correct a malfunction.
- 5.7.32 Atlas Agro must submit a test plan to BCAA for approval at least 30 days prior to initial performance testing, and any subsequent stack testing, or RATA as applicable and pursuant to Procedure 1 of appendix F of 40 CFR Part 60.

- 5.7.33 Atlas Agro must submit the report results of all compliance demonstration performance testing no later than 45 60 calendar days after completion of each respective source test.
- 5.7.34 The hourly, daily and monthly data based on rolling averages of the data as required and specified by this Order shall be reported BCAA on a monthly basis. The data shall be reported on or before the 10th day of the following month of each calendar month as specified in this Order.
- 5.7.35 A summary of compliance and records shall be submitted to BCAA on a semiannual every six months. The record shall be submitted on or before July 10th and January 10th. July 10th shall be for the period from January 1st to June 30th and January 10th shall be for the period from July 1st through December 31st of every year. The record of the summary of the compliance shall include each approval conditions in this order and specify if the Facility was following the condition and if it was complying with the condition or not. If not, the reason why it was not in compliance with the condition.

Monthly Qualitative Assessment

- 5.7.36 A qualitative assessment of the visual emissions of each operating emission unit shall be conducted monthly by the Permittee and recorded. Personnel shall be certified and thoroughly knowledgeable of the “Visible Emissions Field Manual: Methods 9 and 22”. If, at any time, visible emission occurs that has the potential to exceed the applicable standard or specified in this Order, the Permittee shall take the following action(s):
- 5.7.36.1 Verify that the emission unit causing the visible emission and its associated control devices are operating according to manufacturer’s specifications or other site-specific acceptable operating conditions. If the unit or control devices are not operating properly, the Permittee shall take corrective action immediately to bring the unit into compliance.
- 5.7.36.2 If the corrective action does not bring the unit into compliance within four (4) hours, the Permittee shall report the process upset conditions under condition 5.7.38 “Excess Emissions”. The Permittee shall continue to take corrective action to bring the unit into compliance.
- 5.7.36.3 If the corrective action taken does not bring the unit into compliance within twelve (12) hours, the Permittee shall discontinue and shutdown the operation of the unit until such time that compliance can be achieved. The Permittee shall verify compliance by conducting opacity reading using 40 CFR 60 Appendix A, Method 9 or Method 22. The opacity and the report shall be prepared and submitted to BCAA within five (5) working days of the test.

Unavoidable Excess Emissions

- 5.7.37 The Permittee shall have the burden of proving to BCAA that excess emissions were unavoidable. Excess emissions determined to be unavoidable under procedures and criteria in WAC 173-400-108 shall be excused and not subject to penalty only as also specified in WAC 173-400-109.
- 5.7.37.1 Excess emission due to startup or shutdown shall be considered unavoidable, if the source reports in accordance with the requirements of BCAA Regulation 1 and WAC 173-400-108(3). The report must demonstrate adequately that excess emissions could not have been prevented through careful planning and design and if a bypass of the control equipment occurs, such that a bypass is necessary to prevent loss of life, personal injury, or severe property damage.
 - 5.7.37.2 Excess emission due to scheduled maintenance shall be considered unavoidable if the source reports as required under WAC 173-400-108(3) and adequately demonstrate that the excess emissions could not have been avoided through reasonable design and better scheduling for maintenance or through better operation and maintenance practices.
 - 5.7.37.3 Excess emission due to upsets shall be considered unavoidable provided the source reports as required under WAC 173-400-108(3) and adequately demonstrated as per WAC 173-400-109(4).
 - 5.7.37.4 The event was not caused by poor design, operation, maintenance, or any other reasonably preventable condition as required by WAC 173-400-108(4)(a).
 - 5.7.37.5 The event was not of a recurring pattern indicative of inadequate design, operation, or maintenance; and per WAC 173-400-109(5)(a).
 - 5.7.37.6 The operator took immediate corrective action in a manner consistent with good air pollution control practice to minimize emissions during the event, taking into account, the total emissions impact of the corrective action, including slowing or shutting down the emission unit as necessary to minimize emissions, when the operator knew or should have known that an emission standard or permit condition was being exceeded as specified by WAC 173-400-109(5)(a).

Reporting Excess Emissions

- 5.7.38 The Permittee shall report to BCAA all excess emissions pursuant to the criteria in WAC 173-400- 108 and 109 as follows:
- 5.7.38.1 Excess emissions, which represent a potential threat to human health or safety that the Facility believes to be unavoidable, shall be reported to the BCAA within twelve (12) hours after the deviation is discovered.
 - 5.7.38.2 Excess emissions shall be reported to the BCAA according to WAC 173-400-108 and 109 and the report shall provide sufficient documentation as per WAC 173-400-108(4) or 173-400-109(5).

OPERATIONS AND MAINTENANCE MANUAL

- 5.7.39 Atlas Agro shall develop and implement an O&M plan which identifies operational parameters and practices that constitute proper operation relative to compliance with the emission limitation conditions of this Order.
- 5.7.40 Atlas Agro must include these operational parameters and practices in the O&M Plan. The O&M manual shall include at minimum the following and as specified in this Order:
- 5.7.40.1 Manufacturers' operating instructions and design specifications.
- 5.7.40.2 Normal operating parameters.
- 5.7.40.3 Updates to reflect any modification of the equipment or its operating procedures.
- 5.7.41 Atlas Agro will keep the operational parameters and practices in the O&M manual up to date to the extent that they relate to the air emission limitations and operating requirements.
- 5.7.42 Atlas Agro will keep the O&M manual readily available at Facility for review by state, federal, and local agencies.
- 5.7.43 Within thirty days of any request from BCAA, Atlas Agro shall submit the O&M plan to the agency for approval of any elements relevant to the air emission limitations.
- 5.7.44 Subject to RCW 70A.15.2500, Atlas Agro will permit the Environmental Protection Agency, state and local regulatory personnel access to the Source upon request for the purposes of compliance assurance inspections.
- 5.7.45 Nothing in this determination shall be construed so as to relieve Atlas Agro of its obligations under any state, local, or federal laws or regulations.

CALCULATIONS:

- 5.7.46 Atlas must calculate the 30 operating day rolling arithmetic average emissions rate in units of the applicable emissions standard (lb NO_x/ton 100 percent acid produced) at the end of each operating day using all of the quality assured hourly average CEMS data for the previous 30 operating days.
- 5.7.47 Atlas must calculate the 30 operating day average emissions rate according to the Equation below:

$$E_{30} = k \frac{1}{n} \sum_{i=1}^n C_i Q_i / P_i$$

Where:

E_{30} = 30 operating day average emissions rate of NO_x , lb NO_x /ton of 100 percent HNO_3 ;
 C_i = concentration of NO_x for hour i , ppmv;
 Q_i = volumetric flow rate of effluent gas for hour i , where C_i and Q_i are on the same basis (either wet or dry), scf/hr;
 P_i = total acid produced during production hour i , tons 100 percent HNO_3 ;
 k = conversion factor, 1.194×10^{-7} for NO_x ; and
 n = number of operating hours in the 30 operating day period, i.e., n is between 30 and 720.

6. GENERAL APPROVAL CONDITIONS

- 6.1 The issuance of any Compliance Order, Regulatory Order, Order of Approval, or any other Order to the Facility by the BCAA or the addition, modification, or removal of any equipment shall be grounds for review of this Regulatory Order. Upon review, this Order shall be revised or rescinded by the BCAA as necessary.
- 6.2 A copy of this Order shall be on-site in a location known and available to personnel in direct operation of the emission units and available to the BCAA, Department of Ecology, or EPA staff upon request.
- 6.3 Operation of equipment must be conducted in compliance with all data and specification submitted as part of the Notice of Construction application unless otherwise approved by BCAA. Any activity undertaken by the Permittee, or others, in a manner which is inconsistent with the application or this Order, shall be subject to BCAA enforcement under applicable regulations.
- 6.7 The Permittee shall prevent the emission of any air contaminant from any source if it is detrimental to the health, safety, or welfare of any person, or causes damage to property or business.
- 6.8 This Facility shall be registered with the BCAA as an air pollution source and must comply with the source registration program according to BCAA Regulation 1 as a synthetic minor.
- 6.9 Access to the Facility by BCAA staff shall be allowed upon request for conducting compliance inspections. Denial of entry to BCAA staff by the Permittee is grounds for revocation of this Order.
- 6.10 Records of all data shall be kept on-site in a readily retrievable manner for a period of five (5) years from any current date or a rolling average and be made available to authorized representatives of the BCAA, the Department of Ecology, or the EPA, within 48 hours of request or upon request.
- 6.11 This Order shall be non-transferable and shall only apply to the Facility and specified equipment.
- 6.12 This Order shall become invalid if construction does not commence within eighteen (18) months after receipt of the final approval or if construction is discontinued for a

period of eighteen (18) months or more. The BCAA may extend this period upon a satisfactory demonstration that an extension is justified.

- 6.13 This Order shall be rescinded if operation of the Facility is discontinued for a period of twelve (12) months or more. The BCAA may extend this period upon satisfactory reasoning showing that an extension is justified.
- 6.14 If the owner or operator at this site changes, notification for the changes shall be given to the BCAA in writing within thirty (30) days of the change.
- 6.15 The Permittee must provide, within a reasonable time, any information that BCAA may request in writing to determine whether cause exists for modifying, revoking and reissuing, or terminating the Order for determining compliance with the Order. Upon request, the Permittee shall also provide BCAA copies of recordkeeping required to be maintained by the Order or, for information claimed to be confidential, the Permittee should also furnish such records directly with the administrator along with a claim of confidentiality as specified above. Permitting authorities shall maintain confidentiality of such information according to RCW 70A.15.2510.
- 6.16 Air quality violations, including failure to meet the conditions of this Order, shall be subject to any of the remedies provided in RCW 70A.15. Such remedies include notice of violations, Order, and civil penalty of up to \$10,000 per day per violation.
- 6.17 Nothing in this approval shall be construed as preventing compliance with any requirement(s) of law, including those imposed pursuant to the Washington Clean Air Act, and rules and regulations thereunder, or any other regulations.
- 6.18 This Order may be modified, suspended or revoked in whole or part for cause including, but not limited to, the following:
 - 6.18.1 Violation of any terms or conditions of this authorization; or
 - 6.18.2 If this authorization has been obtained by misrepresentation or failure to disclose fully all relevant facts.
- 6.19 The provisions of this authorization are severable and, if any provision of this authorization, or application of any provisions of this authorization to any circumstance, is held invalid, the application of such provision to their circumstances, and the remainder of this authorization, shall not be affected thereby.
- 6.20 The requirements of this Order apply to the Facility owner, operator(s), and any contractor or subcontractor performing any activity authorized under this permit. Any person(s), including contractor(s) and subcontractor(s), not in compliance with any of the applicable Order requirements are in violation and may be subject to appropriate civil or criminal penalties. The Facility owner, operator, and all contractor(s) or subcontractor(s) are liable for the actions and violations of their employee(s). Any violation committed by a contractor or subcontractor shall be considered a violation by the Facility owner or operator, and the contractor or any subcontractor(s).
- 6.21 Applicable laws and regulations may be superseded or revised without notice. It is the Permittee's responsibility to stay current with the changes governing their business and therefore the Permittee must comply with all new laws and regulations immediately

upon their effective date. Laws and regulation updates will be incorporated into existing Orders or upon renewal of said Orders of Approval.

- 6.22 Prior to modifying the operation, installing new equipment or changing the quantity set forth in this Order, another NSR application must be filed with BCAA in accordance with WAC 173-400 and BCAA Regulation 1, and an Order must be issued.

You may appeal this Order to the Pollution Control Hearings Board (PCHB) within 30 days of the date of receipt of this Order. The appeal process and applicable requirements is governed by Chapter 43.21B RCW. "Date of receipt" is defined in RCW 43.21B.001(2). To appeal you must do all of the following within 30 days of the date of receipt of this Order:

- File your appeal and copy of this Order with the PCHB, P.O. Box 40903, Olympia, WA, 98504-0903. Filing means actual receipt by the PCHB during regular business hours.
- Serve a copy of your appeal and this Order on BCAA 526 South Steptoe Street, Kennewick, WA 99336, in paper form - by mail or in person. E-mail is not accepted.

Dated at Kennewick, Washington this 2nd day of June, 2025

PREPARED BY:

Tyler Thompson
Air Quality Engineer
Benton Clean Air Agency

REVIEWED BY:

Hasan M. Tahat, Ph.D., P.E.
Air Quality Engineer
Benton Clean Air Agency

APPROVED BY:

Rob Rodger
Executive Director / Air Pollution Control Officer
Benton Clean Air Agency



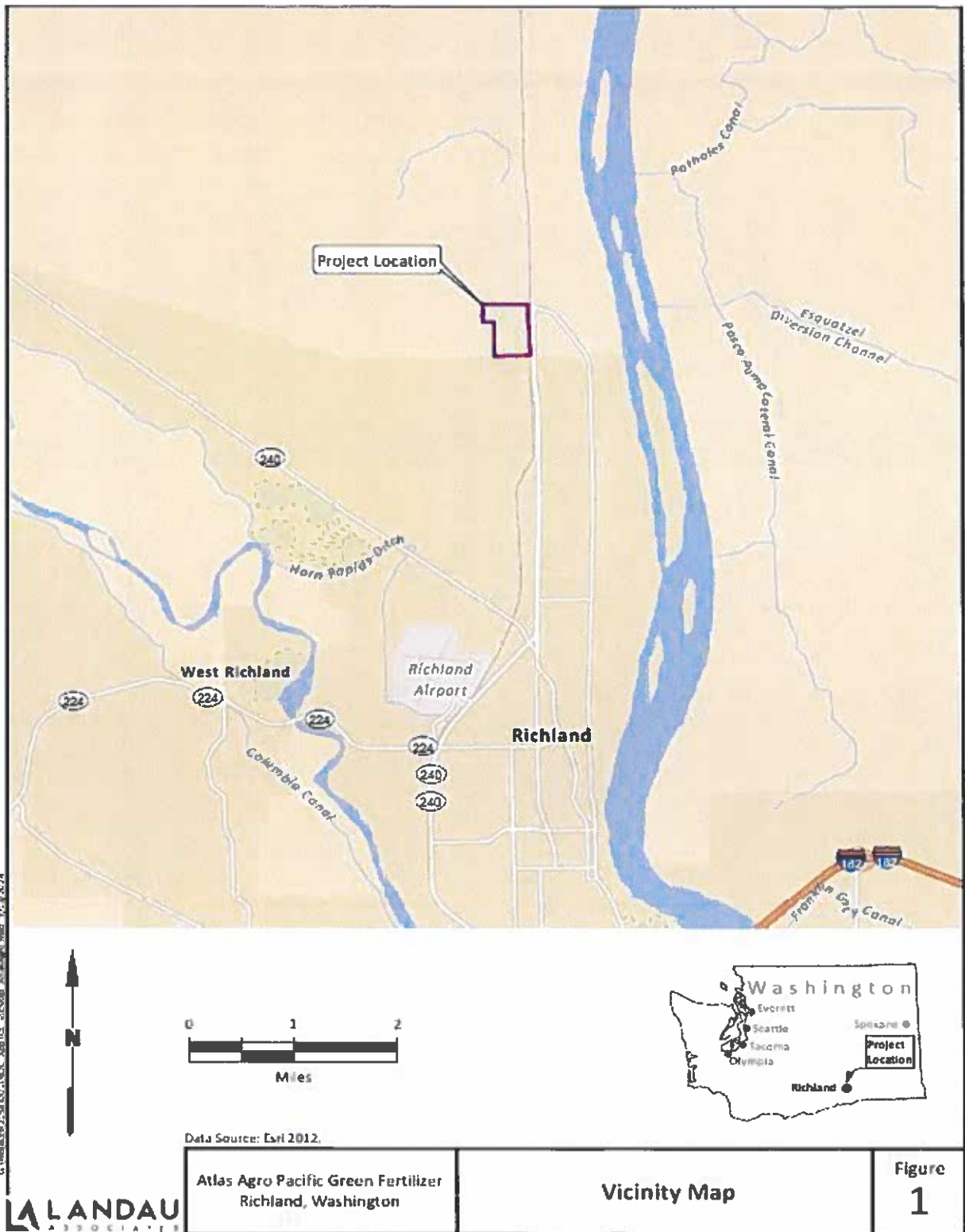

Figure 1. Vicinity Map.

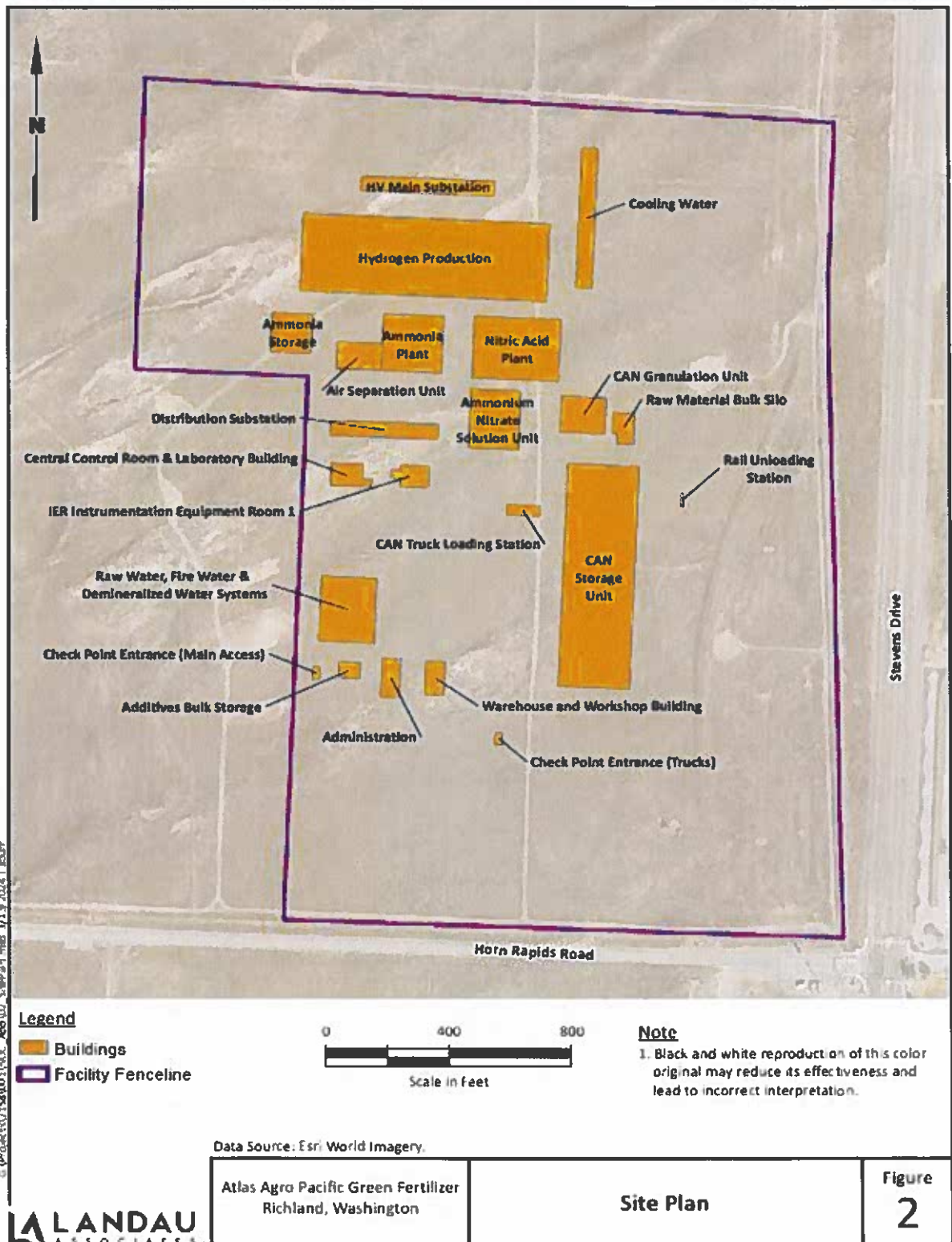
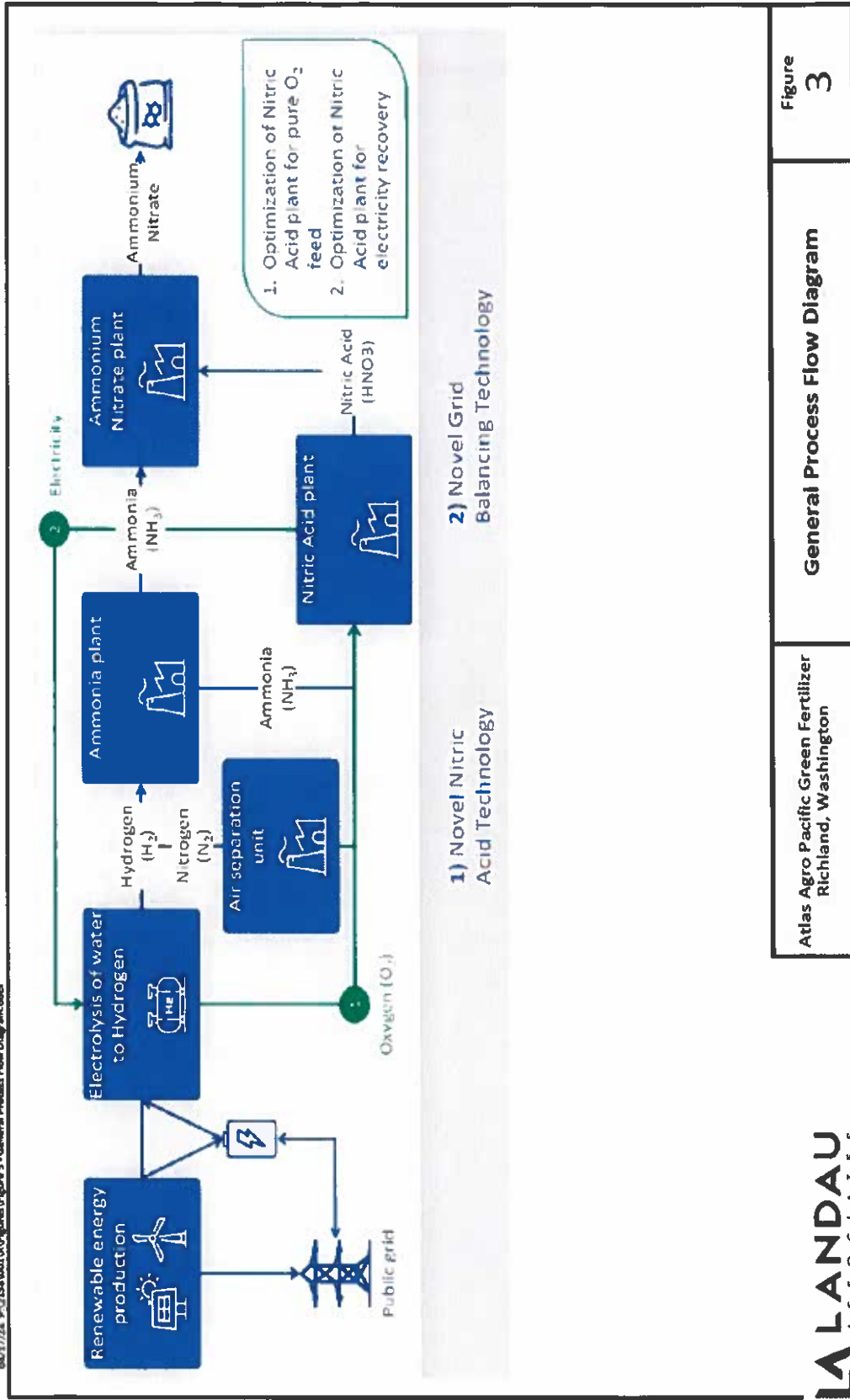

Figure 2. Site Plan

04/17/24 P:\2154\0021\0\Project\Figure 3 - General Process Flow Diagram.docx



Atlas Agro Pacific Green Fertilizer Richland, Washington	General Process Flow Diagram	Figure 3
-------------------------------------------------------------	-------------------------------------	--------------------

Figure 3. General process flow diagram

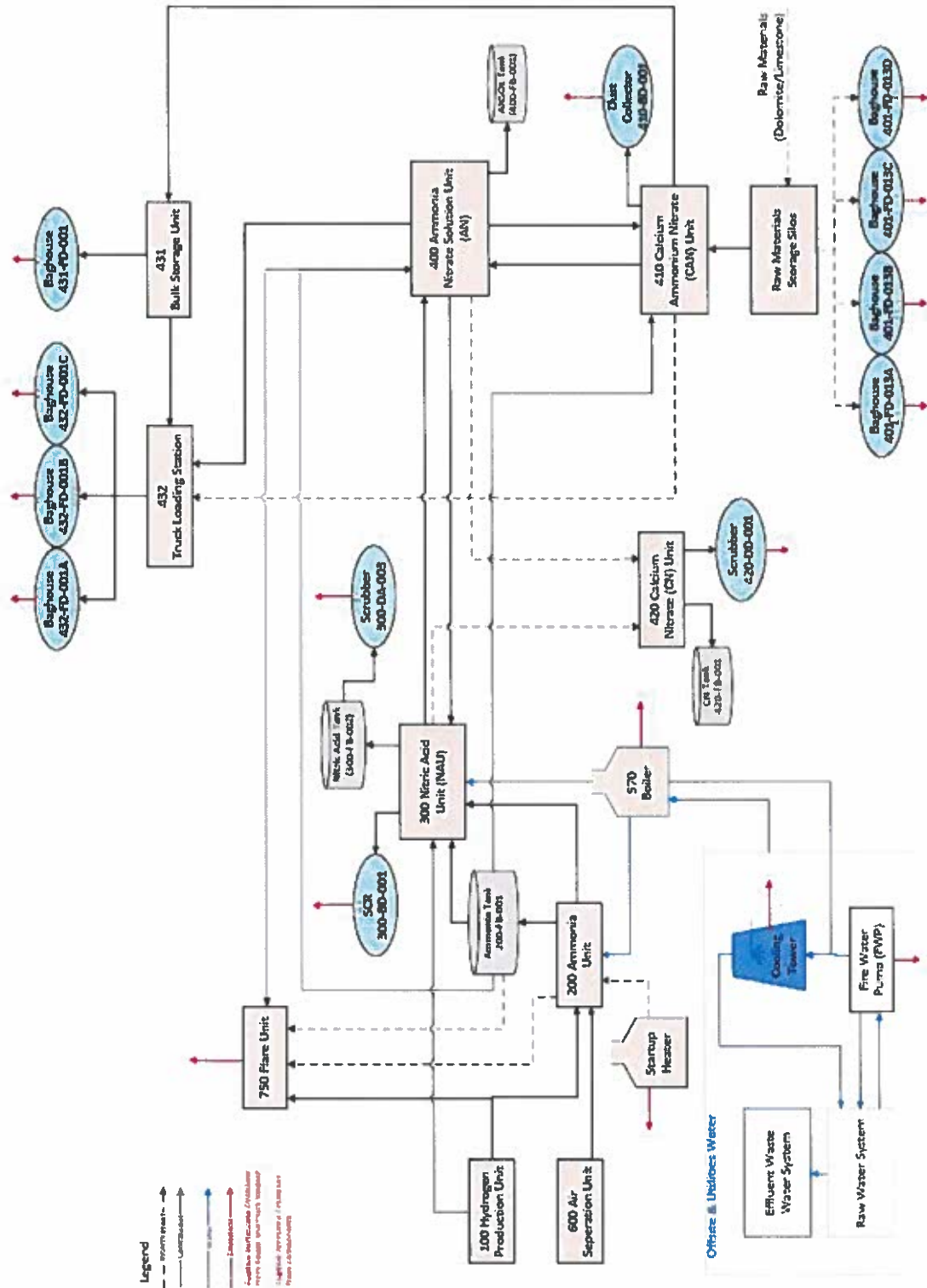
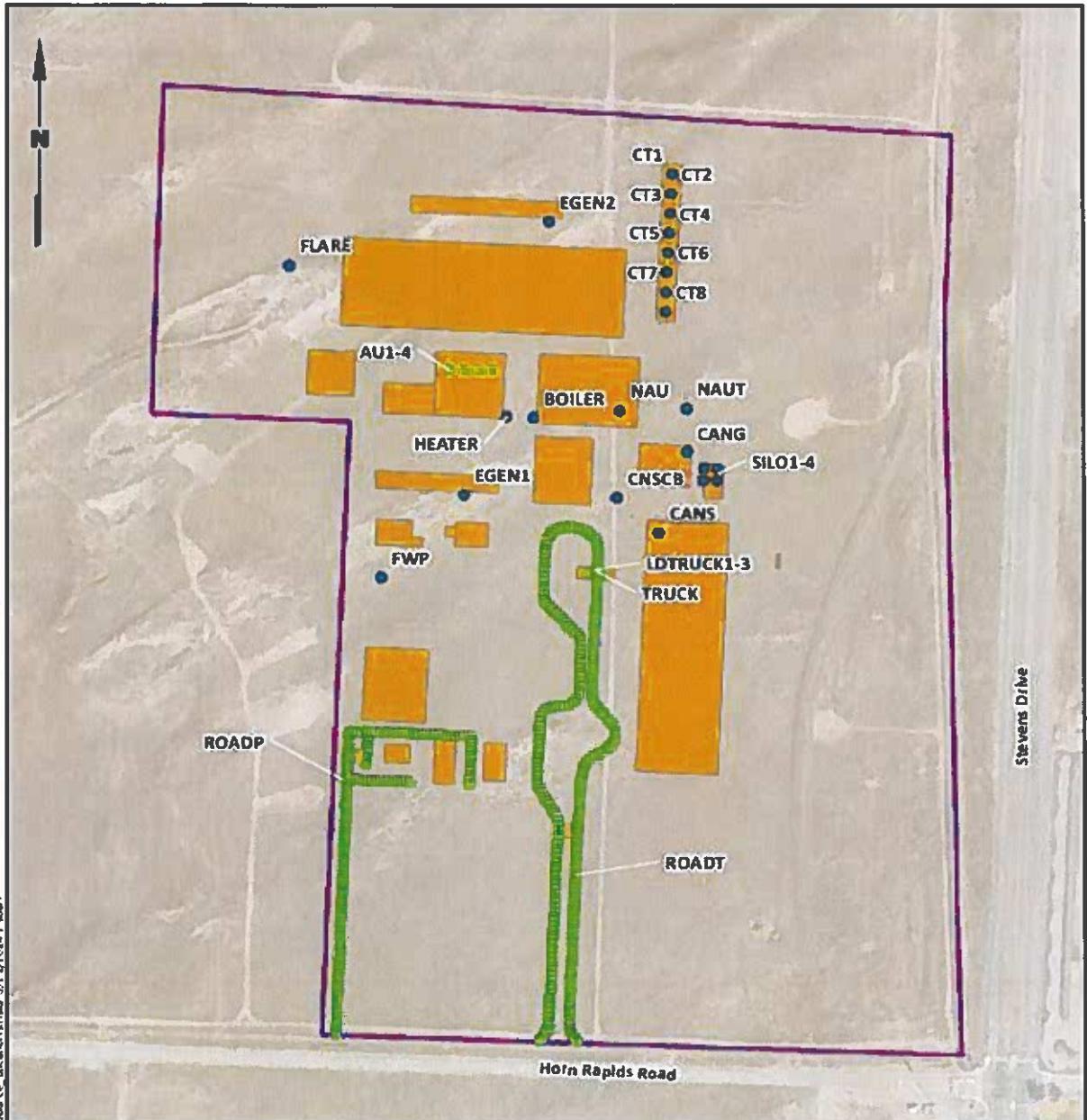
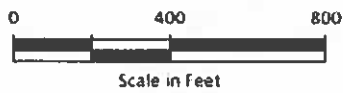

Figure 4. Process flow diagram.



- Legend**
- Point Source
 - Volume Source
 - Buildings
 - Facility Fenceline



Note
 1. Black and white reproduction of this color original may reduce its effectiveness and lead to incorrect interpretation.

Data Source: Esri World Imagery.

Atlas Agro Pacific Green Fertilizer
 Richland, Washington

Point and Volume Source Locations

Figure
5



Figure 5. Point and volume source location

Appendix A

Table 2. Toxic Air Pollutants (TAPs) Emissions Summary
Atlas Agro - Pacific Green Fertilizer Project

CAS No.	Common Name	Averaging Period	ASIL (µg/m3)	SOQR (lb/avg. period)	De Minimis (lb/avg. period)	Total (lb/avg. period)	Over De Minimis?	Modelling Required?	AU	Heater	MAU	CHU	CAWG Emissions (10 Year Averaging period)	CAWS	CAWD	Flare	Boiler	EGen1	EGen2	FWP	
75-07-0	Acetaldehyde	year	0.37	60	3	5.6	Yes	No	Ammonia Unit (AU) Components	Ammonia Plant Startup Heater	Nitric Acid Unit Storage Tank & Scrubber (300-DA-003)	Calcium Nitrate Unit Scrubber (420-GB-001)	Calcium Ammonium Nitrate Unit (410-FD-013A/B/C/D)	Calcium Ammonium Nitrate Unit Raw Storage Dust Collectors (433-FD-001)	Emergency Flare (750-FU-001)	Auxiliary Boiler (570-FU-001)	Diethylfired Emergency Generator #1	Diethylfired Emergency Generator #2	Potential Emissions	Potential Emissions	
107-02-8	Acetone	24-hr	0.35	0.026	0.0013	5.9E-03	Yes	No	---	6.4E-04	---	---	---	---	---	---	1.1E-03	1.1E-03	2.6E-03	4.4E-04	
7440-38-2	Ammonia	24-hr	500	31	1.9	3.4E-02	Yes	Yes	219	2.0E-03	0.54	---	---	---	---	---	3.4E-03	3.1E-03	7.2E-03	1.2E-03	
66-55-3	Aromatic amines, nitro	year	0.0055	0.09	0.045	4.8E-05	No	No	---	1.8E-05	---	---	---	---	---	---	3.5E-02	0.36	0.83	---	
71-43-2	Benzene	year	0.001	0.16	0.0082	6.3E-03	No	No	---	1.2E-05	---	---	---	---	---	---	2.0E-05	1.7E-03	3.9E-03	6.6E-04	
50-37-8	Benzofuran	year	0.0055	0.09	0.045	1.3E-02	No	No	---	1.8E-05	---	---	---	---	---	---	3.0E-05	3.3E-03	7.8E-03	1.3E-03	
205-99-2	Benzothiazole	year	0.0055	0.09	0.045	1.3E-02	No	No	---	1.8E-05	---	---	---	---	---	---	3.0E-05	3.3E-03	7.8E-03	1.3E-03	
207-08-9	Benzothiazole	year	0.0055	0.09	0.045	1.3E-02	No	No	---	1.8E-05	---	---	---	---	---	---	3.0E-05	3.3E-03	7.8E-03	1.3E-03	
7440-41-7	Beryllium & compounds, NOS	year	0.0042	0.068	0.0034	3.2E-04	Yes	No	---	1.2E-04	---	---	---	---	---	---	2.8E-04	---	---	---	
108-99-0	1,3-Butadiene	year	0.033	5.4	0.27	1.5	Yes	No	---	---	---	---	---	---	---	---	---	0.41	1.0	0.16	---
7440-43-9	Chromium & compounds, NOS	year	0.00024	0.039	0.0019	4.0E-03	Yes	Yes	---	1.1E-02	---	---	---	---	---	---	1.8E-02	2.9E-03	6.2E-03	1.1E-03	
CO	Carbon monoxide	1-hr	23000	43	1.1	20	Yes	No	---	2.2	---	---	---	---	---	0.18	---	3.7	8.7	1.5	---
108-90-7	Chlorobenzene	24-hr	1000	74	3.7	2.5E-05	No	No	---	---	---	---	---	---	---	---	---	6.6E-06	1.5E-05	2.8E-06	---
7440-29-9	Chromium(VI) & compounds, NOS	year	0.00004	0.00065	0.000033	7.1E-04	Yes	Yes	---	---	---	---	---	---	---	---	---	---	---	---	---
718-01-9	Cyanide	year	0.055	8.9	0.45	7.0E-03	No	No	---	1.8E-05	---	---	---	---	---	---	---	---	---	---	---
7440-48-4	Cobalt and compounds, NOS	24-hr	0.1	0.0074	0.00037	2.8E-04	No	No	---	6.8E-05	---	---	---	---	---	---	---	---	---	---	---
7440-50-8	Copper & compounds	1-hr	100	0.19	0.0093	5.8E-04	No	No	---	2.9E-05	---	---	---	---	---	---	---	---	---	---	---
57-70-3	Dibenz(a,h)anthracene	year	0.0005	0.082	0.0041	6.6E-03	Yes	No	---	1.2E-05	---	---	---	---	---	---	---	---	---	---	---
106-46-7	1,4-Dichlorobenzene	year	0.091	15	0.74	3.2E-02	No	No	---	1.2E-02	---	---	---	---	---	---	---	---	---	---	---
500-00-0	DEHP	year	0.0030	0.54	0.027	11	Yes	Yes	---	---	---	---	---	---	---	---	---	---	---	---	---
57-97-6	7,12-Dimethylcyclopentadiene	year	0.000005	0.0014	0.000069	4.3E-04	Yes	No	---	1.5E-04	---	---	---	---	---	---	---	---	---	---	---
100-51-4	Ethyl benzene	year	0.4	65	3.2	0.13	No	No	---	2.0E-02	---	---	---	---	---	---	---	---	---	---	---
50-00-0	Formaldehyde	year	0.17	27	1.4	14	Yes	No	---	7.5E-01	---	---	---	---	---	---	---	---	---	---	---
110-54-3	n-Hexane	24-hr	700	53	2.6	3.9	Yes	No	---	1.4	---	---	---	---	---	---	---	---	---	---	---
7667-01-0	Methyl chloride	24-hr	9	6.07	0.033	2.3E-02	No	No	---	---	---	---	---	---	---	---	---	---	---	---	---
193-39-5	Methyl ethyl ketone	year	0.0055	0.89	0.045	6.8E-03	No	No	---	1.8E-05	---	---	---	---	---	---	---	---	---	---	---
7439-92-1	Lead & compounds, NOS	year	0.003	14	10	7.3E-02	No	No	---	5.0E-03	---	---	---	---	---	---	---	---	---	---	---
7439-96-5	Melamine & compounds	24-hr	0.3	0.022	0.0011	1.2E-03	Yes	No	---	3.1E-04	---	---	---	---	---	---	---	---	---	---	---
7439-97-6	Mercury, elemental	24-hr	0.03	0.0022	0.00011	8.0E-04	Yes	No	---	1.8E-04	---	---	---	---	---	---	---	---	---	---	---
7439-99-5	3-Methylthiophene	year	0.000096	0.016	0.00078	4.8E-05	No	No	---	1.8E-05	---	---	---	---	---	---	---	---	---	---	---
91-20-3	Naphthalene	year	0.029	4.8	0.24	0.27	Yes	No	---	6.1E-03	---	---	---	---	---	---	---	---	---	---	---
7440-02-0	Nickel & compounds, NOS	year	0.0038	0.12	0.011	8.4E-02	Yes	No	---	2.1E-02	---	---	---	---	---	---	---	---	---	---	---
7697-37-2	Nitric acid	1-hr	86	0.16	0.006	4.1E-02	Yes	No	---	4.1E-02	---	---	---	---	---	---	---	---	---	---	---
7440-03-0	Nitrogen dioxide	1-hr	470	6.87	0.46	13	Yes	Yes	---	1.4	10.4	5.8	---	---	---	0.7	2.4	0.7	1.7	1.7	
115-07-1	Propylene	24-hr	3000	220	11	9.1E-02	No	No	---	1.2E-02	---	---	---	---	---	---	---	---	---	---	---
7440-05-2	Sulfur dioxide	1-hr	600	1.2	0.46	2.1E-02	No	No	---	2.0E-02	---	---	---	---	---	---	---	---	---	---	---
108-88-3	Toluene	24-hr	5000	370	19	6.1E-02	No	No	---	1.9E-03	---	---	---	---	---	---	---	---	---	---	---
7440-62-2	Sodium (fine or dust)	24-hr	0.1	0.0074	0.00037	4.9E-03	Yes	No	---	1.9E-03	---	---	---	---	---	---	---	---	---	---	---
1330-20-7	Various (mixtures) including m-xylene, o-xylene, p-xylene	24-hr	220	16	0.82	1.8E-02	No	No	---	4.7E-03	---	---	---	---	---	---	---	---	---	---	---
108-28-3	m-Xylene	24-hr	220	16	0.82	2.7E-03	No	No	---	---	---	---	---	---	---	---	---	---	---	---	---
95-47-6	o-Xylene	24-hr	220	16	0.82	2.6E-03	No	No	---	---	---	---	---	---	---	---	---	---	---	---	---

Table 3. Hazardous Air Pollutants (HAPs) Emission Summary
Atlas Agro - Pacific Green Fertilizer Project

CAS No.	Common Name	Threshold (tons/yr)	Facility-Wide Total Emissions (tons/yr)	AU	Heater	MAU	MAUT	CNU	CANG	CANS	CAMD	Flare	Boiler	EGen1	EGen2	FWP	CT	Load	Road
75-07-0	Acetaldehyde	2.80E-03	2.80E-03	Ammonia Unit (AU) Components	4.5E-06			Calcium Nitrate Unit Scrubber (420-GB-001)	Calcium Ammonium Nitrate Unit Granulator Stack (410-BD-001)	Calcium Ammonium Nitrate Unit Raw Material Reducing to Silos Emissions (410-FD-013A/B/C/D)	Calcium Ammonium Nitrate Products Storage Dust Collectors (431-FD-001, 432-FD-001 A/B/C, 433-FD-001)	Emergency Flare (750-PU-001)	Auxiliary Boiler (570-PU-001)	Potential Emissions Diesel-Fired Emergency Generator #1	Potential Emissions Diesel-Fired Emergency Generator #2	Potential Emissions Diesel-Fired Fire Water Pump (FWP)	Cooling Tower (560-PU-001)	Product Load-out Potential Fugitive Emissions	Paved Road Potential Fugitive Emissions
107-02-8	Acrolein	1.32E-04	1.32E-04		4.0E-06								7.5E-06	7.5E-04	1.8E-03	2.9E-04			
7440-38-2	Arsenic	8.38E-06	8.38E-06		1.0E-06								1.7E-06	1.5E-06	3.6E-06	6.0E-07			
71-43-2	Benzene	6.92E-04	6.92E-04		1.1E-05								1.8E-05	1.8E-04	4.2E-04	7.0E-05			
7440-41-7	Beryllium	1.61E-07	1.61E-07		6.0E-08								1.0E-07						
7440-43-9	Cadmium	2.01E-05	2.01E-05		5.5E-06								9.2E-06	1.4E-06	3.4E-06	5.6E-07			
7440-47-3	Chromium (total)	2.09E-05	2.09E-05		7.0E-06								1.2E-05	5.7E-07	1.3E-06	2.3E-07			
7440-48-4	Cobalt	1.13E-06	1.13E-06		4.2E-07								7.0E-07						
106-46-7	Dichlorobenzene	1.61E-05	1.61E-05		6.0E-06								1.0E-05						
100-41-4	Ethylbenzene	6.57E-05	6.57E-05		1.0E-05								1.7E-05	1.0E-05	2.4E-05	4.1E-06			
50-00-0	Formaldehyde	7.16E-03	7.16E-03		3.8E-04								6.3E-04	1.6E-03	3.9E-03	6.5E-04			
110-54-3	Hexane	2.42E-02	2.42E-02		9.1E-03								1.5E-02	2.6E-05	6.0E-05	1.0E-05			
7439-92-1	Lead	3.63E-05	3.63E-05		2.5E-06								4.2E-06	7.9E-06	1.9E-05	3.1E-06			
7439-96-5	Manganese	1.61E-05	1.61E-05		1.9E-06								3.2E-06	3.0E-06	6.9E-06	1.2E-06			
7439-97-6	Mercury	1.06E-05	1.06E-05		1.3E-06								2.2E-06	1.9E-06	4.5E-06	7.5E-07			
91-20-3	Naphthalene	1.35E-04	1.35E-04		3.1E-06								5.1E-06	3.4E-05	8.0E-05	1.3E-05			
7440-02-0	Nickel	4.21E-05	4.21E-05		1.1E-05								1.8E-05	3.7E-06	8.7E-06	1.5E-06			
	Polycyclic Organic Matter (POM)	3.51E-06	3.51E-06		3.5E-06								0.0E+00						
108-88-3	Toluene	4.80E-04	4.80E-04		3.9E-05								6.5E-05	1.0E-04	2.4E-04	4.0E-05			
1330-20-7	Xylenes	2.29E-04	2.29E-04		2.9E-05								4.9E-05	4.0E-05	9.5E-05	1.6E-05			
106-99-0	1,3-Butadiene	7.75E-04	7.75E-04											2.1E-04	4.9E-04	8.2E-05			
108-90-7	Chlorobenzene	7.13E-07	7.13E-07											1.9E-07	4.5E-07	7.5E-08			
18540-29-9	Chromium (VI)	3.56E-07	3.56E-07											9.5E-08	2.2E-07	3.8E-08			
7647-01-0	Hydrogen chloride	6.64E-04	6.64E-04											1.8E-04	4.2E-04	7.0E-05			
95-47-6	o-Xylene	7.45E-05	7.45E-05											2.0E-05	4.7E-05	7.8E-06			
108-38-3	m-Xylene	7.69E-05	7.69E-05											2.1E-05	4.8E-05	8.1E-06			
HAP	Total HAP's	3.75E-02	25		9.6E-03								1.6E-02	3.2E-03	7.5E-03	1.3E-03			
110-54-3	Single Highest HAP (Hexane)	2.42E-02	30		9.1E-03								1.5E-02	2.6E-05	6.0E-05	1.0E-05			

Table 4. Summary Site-wide Potential with requested enforceable limits and without requested enforceable limits
Atlas Agro- Pacific Green Fertilizer Project
 Site-wide potential air emissions summary (with requested enforceable limits)

ID	Emission Point	Criteria Pollutant Emissions (tpy)										Greenhouse Gas Emissions (MT/yr)					HAP (tpy)	
		NOx	CO	SO2	PM	PM10	PM2.5	VOC	CO2e	CO2	CH4	N2O	Hexane	Total HAP				
AU	Ammonia Unit (AU) Components (200)	
Heater	Ammonia Plant Startup Heater	0.21	0.32	3.0E-03	3.8E-02	3.8E-02	3.8E-02	2.8E-02	545	1.03E-02	1.03E-03	9.05E-03	9.6E-03					
NAU	Nitric Acid Unit Exhaust (300-BD-001)	46.67	68,433	...	229.64					
NAU1	Nitric Acid Unit Storage Tank & Scrubber (300-DA-003)	3.21					
CNU	Calcium Nitrate Unit Scrubber (420-GB-001)	20.09	17,308	17,308					
CANG	Calcium Ammonium Nitrate Unit Granulator Stack (410-BD-001)	75,754	75,754					
CAN1	Calcium Ammonium Nitrate Unit Raw Material Receiving to Silos					
CAN2	Calcium Ammonium Nitrate Products Storage Dust Collectors (431-)					
Flare	Emergency Flare (750-PU-001)	2.90	1.20	2.6E-03	4.3E-01	4.3E-01	4.3E-01	2.8E+00					
Boiler	Auxiliary Boiler (570-PU-001)	0.36	0.54	5.0E-03	3.2E-02	3.2E-02	3.2E-02	2.3E-02	908	907	1.71E-02	1.51E-02	1.6E-02					
EGen1	Diesel-Fired Emergency Generator #1 Potential Emissions	0.02	0.11	2.0E-04	9.2E-04	9.2E-04	9.2E-04	6.4E-02	19	19	7.84E-04	1.57E-04	3.2E-03					
EGen2	Diesel-Fired Emergency Generator #2 Potential Emissions	0.05	0.25	4.6E-04	2.2E-03	2.2E-03	2.2E-03	0.01	45	45	1.84E-03	3.68E-04	7.5E-03					
FWP	Diesel-Fired Fire Water Pump (FWP) Potential Emissions	0.05	0.04	5.7E-07	2.4E-03	2.4E-03	2.4E-03	0.05	8	8	3.09E-04	6.17E-05	1.3E-03					
CT	Cooling Tower (560-PU-001)					
Load	Product Load-out Potential Fugitive Emissions					
Road	Paved Road Potential Fugitive Emissions					
Totals:		74	2.47	1.13E-02	26.99	27.54	19.08	5.48	163,021	94,586	3,03E-02	230	2.47E-02	3.8E-02				

Thresholds (tpy):		100	100	100	100	100	100	100	100	100	100	100	10	25
Threshold Exceeded?:		No	No	No	No	No	No	No	No	No	No	No	No	No

Site-wide Potential Emissions Summary (Without Requested Enforceable Limits)

ID	Emission Point	Criteria Pollutant Emissions (tpy)										Greenhouse Gas Emissions (MT/yr)					HAP (tpy)	
		NOx	CO	SO2	PM	PM10	PM2.5	VOC	CO2e	CO2	CH4	N2O	Hexane	Total HAP				
AU	Ammonia Unit (AU) Components (200)				
Heater	Ammonia Plant Startup Heater	6.23	9.48	8.8E-02	1.1E+00	1.1E+00	1.1E+00	8.1E-01	15,913	15,896	3,00E-01	3,00E-02	2.64E-01	2.8E-01				
NAU	Nitric Acid Unit Exhaust (300-BD-001)	46.67	68,433	...	229.64					
NAU1	Nitric Acid Unit Storage Tank & Scrubber (300-DA-003)	3.21					
CNU	Calcium Nitrate Unit Scrubber (420-GB-001)	42.92	36,980	36,980	0.00E+00	0.00E+00	...					
CANG	Calcium Ammonium Nitrate Unit Granulator Stack (410-BD-001)	75,754	75,754					
CAN1	Calcium Ammonium Nitrate Unit Raw Material Receiving to Silos					
CAN2	Calcium Ammonium Nitrate Products Storage Dust Collectors (431-)					
Flare	Emergency Flare (750-PU-001)	2.90	1.20	2.6E-03	4.3E-01	4.3E-01	4.3E-01	2.8E+00					
Boiler	Auxiliary Boiler (570-PU-001)	0.36	0.54	5.0E-03	3.2E-02	3.2E-02	3.2E-02	2.3E-02	908	907	1.71E-02	1.51E-02	1.6E-02					
EGen1	Diesel-Fired Emergency Generator #1 Potential Emissions	0.02	0.11	2.0E-04	9.2E-04	9.2E-04	9.2E-04	6.4E-02	19	19	7.84E-04	1.57E-04	3.2E-03					
EGen2	Diesel-Fired Emergency Generator #2 Potential Emissions	0.05	0.25	4.6E-04	2.2E-03	2.2E-03	2.2E-03	0.01	157	156	6.34E-03	1.27E-03	2.6E-02					
FWP	Diesel-Fired Fire Water Pump (FWP) Potential Emissions	0.17	0.15	0.00	0.01	0.01	0.01	0.17	26	26	1.06E-03	2.13E-04	4.4E-03					
CT	Cooling Tower (560-PU-001)					
Load	Product Load-out Potential Fugitive Emissions					
Road	Paved Road Potential Fugitive Emissions					
Totals:		113	27.88	2.40E-01	31.88	30.43	21.97	7.72	223,850	155,372	8,09E-01	230	7.05E-01	7.9E-01				

Thresholds (tpy):		100	100	100	100	100	100	100	100	100	100	100	10	25
Threshold Exceeded?:		Yes	No	No	No	No	No	No	No	No	No	No	No	No

**Atlas Agro has requested enforceable operating hour limits on the Ammonia Plant Startup Heater, Auxiliary Boiler, Calcium Nitrate Unit, and Emergency Engines.
 **The operation of the Calcium Nitrate plant is physically limited by the amount of nitric acid the facility can produce. During normal operation, all HNO3 produced will go to making ammonium nitrate solution that is used in the CAN unit. There will be no remaining HNO3 to produce CN.
 ***With the requested enforceable operating limits, facility-wide PTE remains below synthetic minor 80 (SM80) thresholds (i.e., NOx emissions less than 80 tpy.)